

Suggested List Price: US \$25.00

AirSep[®] Corporation
PSA Oxygen Generator
Topaz/Topaz+/Topaz Ultra

Instruction Manual

MN012-2

03/12

Rev. C



AirSep[®] Corporation • 260 Creekside Drive • Buffalo, NY 14228-2075 USA

Phone: 1-800-320-0303 • Fax: (716) 691-1255 • www.airsep.com

Ownership Data

Please take a moment to note below important information about your portable PSA Oxygen Cylinder Filling System. Retain this instruction manual, along with your invoice, to serve as a permanent record of your purchase.

PSA Oxygen System

Model Name:

Serial Number:

Invoice Date:

Start-up Date:

AirSep Representative

Company:

Contact:

Address:

City/Town: State: Zip:

Country: Fax:

Phone: Telex:



Before you attempt to install or operate the oxygen generator, read and thoroughly understand this instruction manual. Improper operation can result in severe bodily injury, damage to the oxygen system, or poor performance.

Table of Contents

1.0	Introduction.....	1-1
1.1	General.....	1-1
1.2	Warnings, Cautions, and Notes.....	1-1
2.0	Safety	2-1
2.1	General.....	2-1
2.2	Potential Hazards	2-1
2.3	Safety Publications	2-2
3.0	System Description	3-1
3.1	General.....	3-1
4.0	Components Description	4-1
4.1	External Components	4-1
4.2	Internal Components	4-3
5.0	Installation	5-1
5.1	Handling and Unpacking	5-1
5.2	Pre-installation Operational Check.....	5-2
5.3	Installation Instructions.....	5-3
6.0	System Operation.....	6-1
6.1	Start-up.....	6-1
6.2	Operation.....	6-1
6.3	Shutdown	6-1
7.0	Maintenance.....	7-1
7.1	Cleaning the Gross Particle Filter.....	7-1
7.2	Cleaning the Enclosure	7-2
7.3	Solenoid Valves.....	7-2
7.4	Air Compressor	7-3
8.0	Troubleshooting.....	8-1
8.1	Technical Support	8-1
8.2	Troubleshooting Chart.....	8-1
A	Appendix: Technical Data	A-1
B	Appendix: Warranty>Returns	B-1
C	Appendix: Parts List	C-1
D	Appendix: Component Literature.....	D-1

List of Illustrations

Figure 4.1 - Oxygen Generator External Components.....	4-1
Figure 4.2 - Oxygen Generator Internal Components.....	4-3
Figure A.1 - Flow Schematic - Topaz.....	A-5
Figure A.2 – Flow Schematic – Topaz+	A-6
Figure A.3 – Flow Schematic – Topaz Ultra	A-7
Figure A.4 – 100/110/120 V, 50 or 60 Hz Electrical Schematic	A-8
Figure A.5 – 240 V, 50 or 60 Hz Electrical Schematic	A-9

1.0 Introduction

1.1 General

This instruction manual provides a description of the AirSep PSA Oxygen Generators – *Topaz/Topaz+/Topaz Ultra* as well as instructions for installation, operation, and maintenance. The Appendix of this instruction manual also provides pertinent drawings and component literature.

To ensure safe operation and proper maintenance of the oxygen generator, AirSep Corporation recommends that you keep this instruction manual readily available for reference.

1.2 Warnings, Cautions, and Notes

As you read the manual, pay special attention to the WARNING, CAUTION, and NOTE messages. They identify safety guidelines or other important information as follows:



Provides information that can prevent severe bodily injury or death.



Provides information that can prevent minor bodily injury or property damage.



Provides information important enough to emphasize or repeat.

2.0 Safety

2.1 General

Oxygen, the most abundant of the elements, makes up approximately 50 percent of the earth's crust. In its free state, it forms about one-fifth of our air by volume. Although oxygen is classified as a non-flammable gas, it supports combustion. As an active element, it combines directly or indirectly with all elements except the rare gases. It is an invisible gas that is colorless, odorless, and tasteless.

To ensure your safety, thoroughly read and familiarize yourself with this section of the manual. AirSep Corporation strongly recommends that you review this section periodically.

2.2 Potential Hazards

Before you attempt to install, operate or repair the oxygen generator, read and thoroughly understand this manual. Improper operation can result in severe bodily injury, damage to the unit, or poor performance.



Oxygen vigorously accelerates the burning of combustible materials. In an oxygen-enriched atmosphere, many materials that do not burn in normal air require only a slight spark or moderate heat to set them aflame.

To avoid fire or an explosion, keep gasoline, kerosene, oil, grease, cotton fibers, paint, and any other combustible material away from any part of the oxygen generator.

Do not smoke or use an open flame near the oxygen generator.

Post "NO SMOKING OR OPEN FLAMES" signs in the area where the oxygen generator is located. AirSep Corporation STRONGLY recommends that only individuals trained and experienced in the safe handling of oxygen operate this unit.



Take extreme care to keep all oxygen piping and vessels clean. To avoid fire or an explosion, oxygen-clean all surfaces that can come in contact with oxygen. Check all oxygen fittings/joints for leaks with an oxygen-compatible leak-detecting solution.



Electrical shock hazard. Only trained personnel may open the oxygen generator. The interior of the oxygen generator contains electrical parts that can produce an electrical hazard if not handled properly.



Connect the oxygen generator power cord to a properly grounded wall outlet on a circuit that cannot be accidentally turned off. Do not use extension cords. Do not position the generator in an area that makes it difficult to disconnect the power.



To prevent fire or electrical shock, locate the oxygen generator indoors away from rain or any other type of moisture.

2.3 Safety Publications

This section is not a complete summary of required safety procedures. Review the following publications for additional information on the safe handling of oxygen:

- “Standard for Bulk Oxygen Systems at Consumer Sites;” NFPA No. 50; National Fire Protection Association; 1 Batterymarch Park; P.O. Box 9101; Quincy, Massachusetts 02269-9101 USA.
- “Oxygen;” Pamphlet G-4; Compressed Gas Association; 1725 Jefferson Davis Highway; Arlington, Virginia 22202-4102 USA.
- “Cleaning Equipment for Oxygen Service;” Pamphlet G-4.1; Compressed Gas Association; 1725 Jefferson Davis Highway; Arlington, Virginia 22202-4102 USA.

3.0 System Description

3.1 General

The AirSep Corporation PSA Oxygen Generator is a self-contained unit that uses Pressure Swing Adsorption (PSA) technology to produce oxygen on site. The PSA process extracts oxygen from ambient air to deliver product oxygen continuously to an application that requires feed oxygen.

The oxygen generator uses compressed air from its internal air compressor as a feed gas to produce the product oxygen. Ambient air enters the air intake, passes through a gross particle filter to remove large airborne particulate matter, then flows into the internal air compressor. The air compressor pressurizes the feed air and delivers the feed air to a heat exchanger for cooling. The cooled, pressurized air then enters one of the adsorber vessels.

The oxygen generator uses in its adsorber vessels an inert ceramic material called molecular sieve to separate compressed air into oxygen and other gases. The unique properties of molecular sieve allow it to attract, or adsorb, nitrogen physically from air under pressure. This allows oxygen to exit the adsorbers as a product gas and flow into a mixing tank, which maintains stable flow and purity of the product oxygen. The product oxygen flows from the mixing tank through a pressure regulator that allows the delivery pressure to be set as required for your application. Finally, the product oxygen flows through a flowmeter, which allows you to set the flow rate required for your application.

While one adsorber produces oxygen, the other depressurizes to exhaust the waste gases it adsorbed (collected) during the oxygen production cycle. The entire oxygen generating process is completely regenerative, which makes it both reliable and virtually maintenance-free. The molecular sieve does not normally require replacement when maintained and used according to this instruction manual.

Refer to the Appendix A of this instruction manual for a detailed flow diagram, an electrical schematic, and specifications for the oxygen generator.

4.0 Components Description

The drawings in this section illustrate the location of the main components of the *Topaz/Topaz+/Topaz Ultra* oxygen generators. All models include similar components unless noted otherwise. Refer to Appendix A of this instruction manual for general layout drawings and specifications.

4.1 External Components

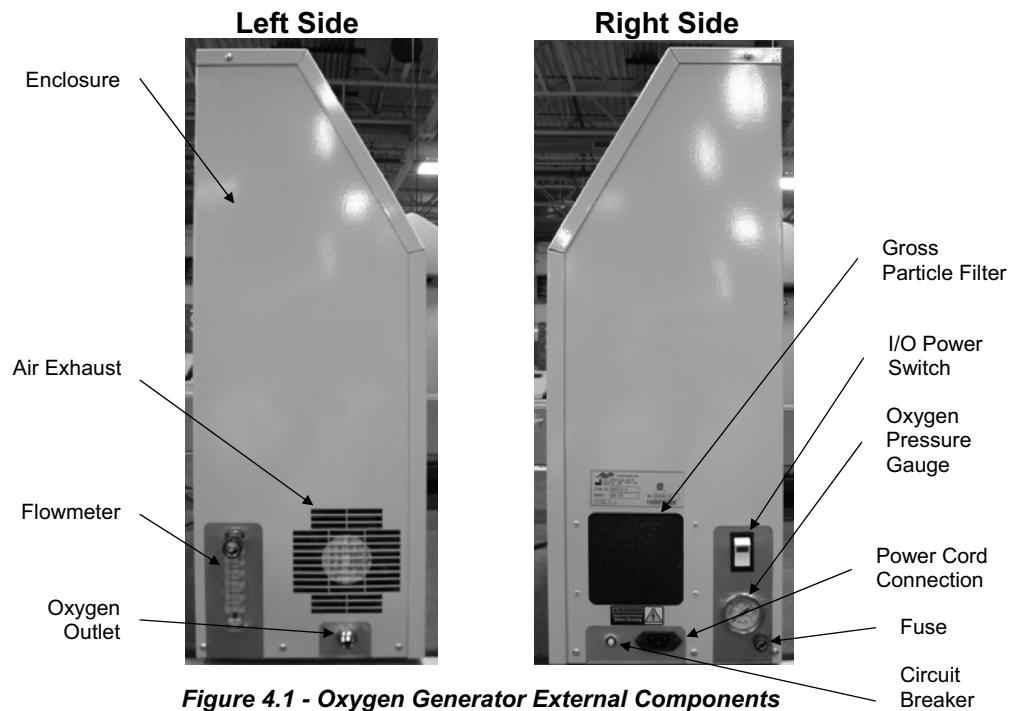

Figure 4.1 - Oxygen Generator External Components

Enclosure

The enclosure protects the components inside the unit (e.g., circuit board, air compressor, and valves).

Gross Particle Filter

The washable gross particle filter removes airborne particulate matter from the room air drawn into the unit.

Oxygen Pressure Gauge

This gauge indicates the delivery pressure of the product oxygen.

Flowmeter

The flowmeter allows you to view and adjust the flow rate of the product oxygen. The flowmeter should never be adjusted beyond the setpoint designated for the unit in Appendix A.



Increasing the flowmeter beyond the setpoint designated for the particular model can potentially cause damage to the molecular sieve and will void the warranty.

Oxygen Outlet

The 'B' size adapter at the oxygen outlet connects to your application.

Air Exhaust

Heat from the unit escapes through the air exhaust, located on the left side of the enclosure.

Power Cord

The power cord (not shown) and its grounded plug connect from a connection (See Figure 4.1) on the unit to a properly grounded electrical outlet to supply electrical power to the unit.

I/O Power Switch

The I/O power switch starts and stops the operation of the unit. When you set the switch to *I*, the green indicator light illuminates.

Circuit Breaker

Use the circuit breaker button to reset the unit after an electrical overload shutdown.

Fuse

For the 240 V units, an additional fuse safety is provided as per the CE regulations.

4.2 Internal Components

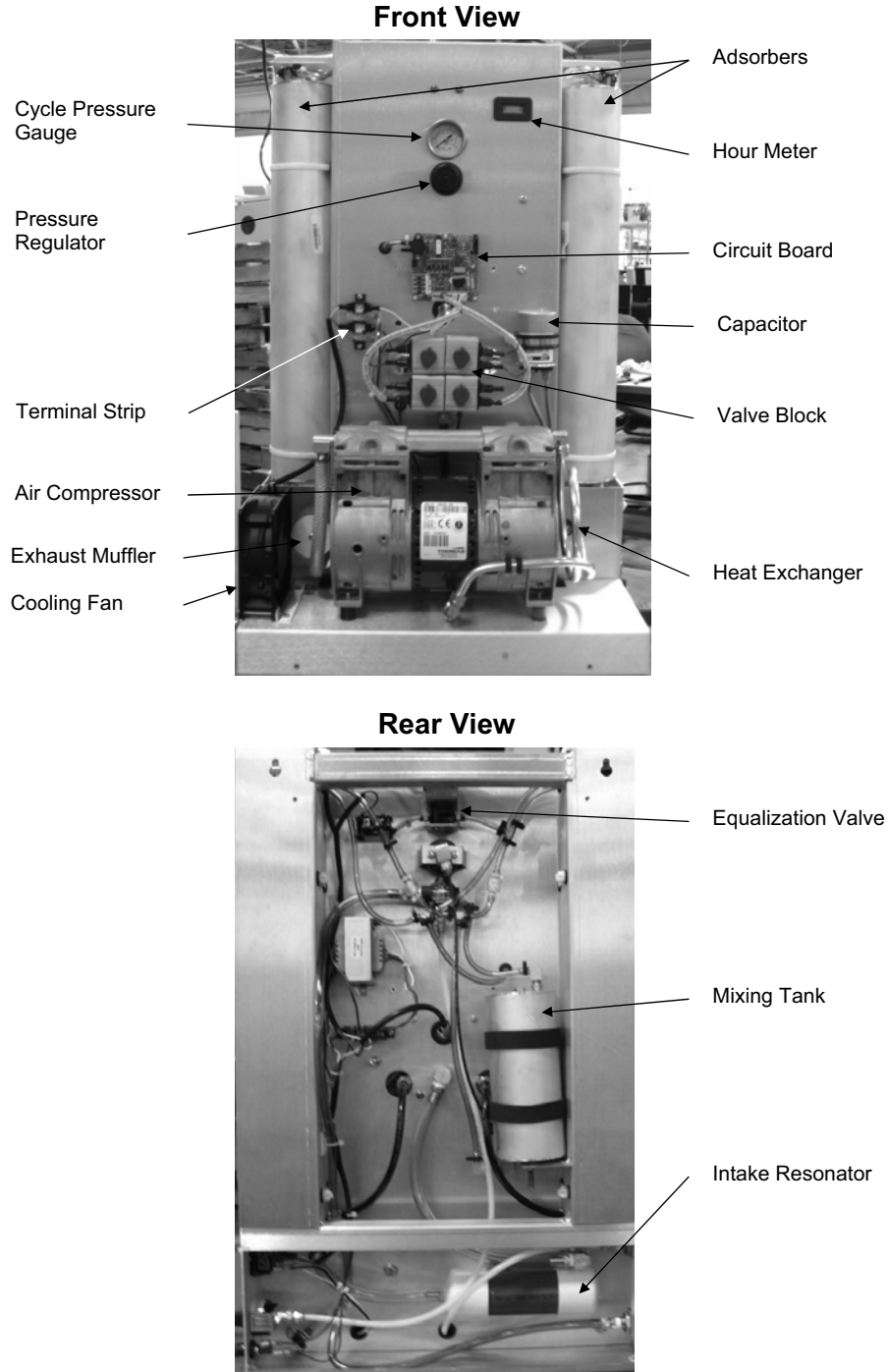

Figure 4.2 - Oxygen Generator Internal Components

Intake Resonator

The intake resonator reduces noise from the air compressor (See Below).

Air Compressor

The air compressor pressurizes ambient air and delivers it to the adsorbers (See Below).

Cooling Fan

The cooling fan increases airflow inside the enclosure to cool the air compressor. The models without enclosures do not have a fan installed.

Capacitor

The capacitor stores additional electrical power to enable the air compressor to start.

Heat Exchanger

The heat exchanger cools the pressurized air from the air compressor.

Adsorbers (Sieve Beds)

The adsorbers, or sieve beds, contain the molecular sieve that adsorbs (attracts) nitrogen from compressed air and allows oxygen to pass through as the product gas.

Cycle Pressure Gauge

The cycle pressure gauge indicates the pressure inside the sieve beds.



The cycle pressure gauge does not indicate the pressure set by the pressure regulator. The oxygen pressure gauge on the right side of the enclosure indicates the pressure set by the pressure regulator.

Valve Block

The valve block houses the solenoid valves.

Equalization Valve

The equalization valve balances the pressure between the two sieve beds.

Circuit Board

The circuit board controls the cycle time and sequence of each solenoid valve.

Terminal Strip

The terminal strip provides a connection point for the wiring to the circuit board and the air compressor.

Mixing Tank

The mixing tank provides stable flow and purity for short-term surge in oxygen demand.

Pressure Regulator

The pressure regulator controls the delivery pressure of the product oxygen. This regulator is factory set and should never be adjusted.



Changing the regulator setpoint in any way can potentially cause damage to the molecular sieve and will void the warranty.

Exhaust Muffler

The exhaust muffler allows waste gas to exit the adsorbers.

Hour Meter

The hour meter indicates the total number of hours that the unit cycles.

5.0 Installation

5.1 Handling and Unpacking

AirSep Corporation ships the oxygen generator in a heavy-duty cardboard carton with two cutout carrying handles. The unit's size and weight allow easy transport by manual lifting; however, the enclosure does not provide handles or wheels because it is intended for stationary operation. To facilitate transport of the oxygen generator, place the unit in the carton and use the handles on the carton to lift the package. Use a hand cart to transport the unit safely to a different location.

To unpack the oxygen generator, follow these guidelines:

- 1) Inspect the shipping carton, and open it immediately upon receipt.
- 2) If the exterior of the carton is severely damaged, note it on the freight bill before you sign it.
- 3) Unpack the unit, and remove any protective wrapping and packaging. Retain the carton and packaging to facilitate future shipping and transporting of the unit.
- 4) Place the unit in an upright position, and thoroughly inspect the enclosure and all external components (e.g., flowmeter) for damage.
- 5) Remove the enclosure, and inspect the interior for loose or damaged parts.



Only trained personnel may open the oxygen generator. To prevent electrical shock, make sure the main power supply is disconnected when you remove the enclosure and inspect the internal components.

- 6) Inspect all wiring to ensure that no wires are broken and no push-on connector is off its terminal.



You must submit a damage claim within 24 hours of delivery. A claim can be filed only by the consignee.

- 7) After inspecting the interior of the enclosure, re-install the enclosure on the unit.

- 8) Locate the plastic bag that contains the instruction manual, extra gross particle filter, and a barb connection for the oxygen outlet. Be sure to read the entire manual before installing and operating the unit.

5.2 Pre-installation Operational Check

Although every oxygen generator is tested thoroughly after it is manufactured, perform the following test to ensure that no damage occurred during shipping and handling:

- 1) Make sure the enclosure fastens securely to the unit.
- 2) Make sure the gross particle filter (See Figure 4.1) completely covers the air intake.
- 3) Make sure the power cord connects securely to the power cord connection (See Figure 4.1) on the unit.
- 4) Connect the power cord to a properly grounded electrical outlet.
- 5) Set the I/O power switch (See Figure 4.1) to *I*. Verify that the green indicator light on the switch illuminates.
- 6) Listen for the sound of the air compressor (See Figure 4.1) in operation.
- 7) Verify that exhaust air emits from the air exhaust (See Figure 4.1) on the left side of the enclosure.
- 8) Rotate the knob on the flowmeter (See Figure 4.1) clockwise until it stops at the fully-closed position. Verify that the flowmeter indicates zero flow.
- 9) Rotate the knob on the flowmeter counterclockwise until the flowmeter indicates the flow specified in Appendix A for the particular model of oxygen generator with nothing connected to the oxygen outlet. The ball in the flowmeter should rise and the oxygen pressure gauge should register 62 kPa (9 psig) for *Topaz* and 138 kPa (20 psig) for *Topaz+* and *Topaz Ultra*. If this does not occur, contact the AirSep Commercial Products Service Department.
- 10) If flowmeter setting is disturbed during shipping, adjust the flowmeter to the flow rate specified. Refer to Appendix A for the specified flow rates.
- 11) Set the I/O power switch to *O*.



Locate the oxygen generator in an area where the ambient air temperature remains between 4°C (40°F) and 40°C (104°F) to prevent damage not covered under the AirSep Corporation Product Warranty.



The generator should only be used in the manner specified in the manual to prevent damage not covered in the AirSep Corporation Product Warranty.



AirSep oxygen generators are sold for indoor use only. Make sure the area that surrounds the oxygen generator is well ventilated, and provide sufficient space around the unit [at least one meter (three feet)] to allow for cool air flow as well as to allow safe operation and maintenance.

5.3 Installation Instructions

- 1) To ensure optimum performance of the oxygen generator and prevent damage not covered under the AirSep Corporation Product Warranty, make sure location of the unit meets the following conditions:
 - Locate the unit in an area that is protected from the weather elements and where the ambient temperature remains within the specifications in the Appendix A of this instruction manual.
 - To enable adequate airflow to cool the unit, locate the unit away from any source of heat, and make sure the sides of the unit remain at least six inches away from any wall or other obstruction.
 - Locate the unit within ten feet of a grounded electrical outlet that cannot be turned off accidentally.



Do not position the equipment in an area that makes it difficult to disconnect the power.
Do not use extension cords with the oxygen generator.

- Connect the unit to electrical power that continuously meets the specifications in the Appendix A of this instruction manual.

- 2) Place the oxygen generator in an upright position on a level surface.
- 3) Connect the oxygen outlet to the inlet of your application.



Use only oxygen-compatible materials for the hoses, tubing, and connections between the oxygen outlet and the inlet to your application.

If you use tubing at the inlet to your application, connect to the oxygen outlet the barb and fastener provided in the plastic bag shipped with the unit. Insert the barb into the tubing connected to your application, and clamp the tubing securely to the barb.



Clean your hands thoroughly before handling the barb and fastener. Make sure the tools used to secure the connection between the oxygen outlet and your application does not contaminate the hoses, tubing, or connections with oil or other petroleum-based products.



If a continuous supply of oxygen is critical to your application, provide a backup source of oxygen to use if a power failure or equipment malfunction occurs.

6.0 System Operation

When you complete installation as described in the previous section, the oxygen generator is ready for easy start-up and operation.

6.1 Start-up

- 1) Set the I/O power switch to *I*, and wait two minutes to allow the product oxygen to attain the purity specified in the Appendix A of this instruction manual.

Rotate the flowmeter knob counterclockwise to increase flow or clockwise to decrease flow as required for your application. The flowmeter must never indicate a setting higher than that specified in Appendix A for the particular model.

- 2) The flowmeter must be set at the specified flow rate. Refer to Appendix A for the specified flow rates. At the appropriate flowrate setting, top of the ball of the flowmeter will be at the level mark.



NOTE

Increasing the flow of the product oxygen above the flow specified in Appendix A of this instruction manual results in reduced purity of the product oxygen, potential damage to the molecular sieve and the warranty will be voided.

- 3) Begin oxygen use by your application.

6.2 Operation

The oxygen generator operates automatically after start-up. Monitor the performance of the oxygen generator at regular intervals to make sure the product oxygen remains within the specifications (Refer to Appendix A of this instruction manual).

6.3 Shutdown

- 1) To stop oxygen delivery, rotate the flowmeter knob clockwise until the flowmeter registers zero.
- 2) Set the I/O power switch to *O*.



Using the oxygen generator at flows higher than 15% above those specified in Appendix A of this manual, will result in the likely contamination of the molecular sieve beds. This damage is not covered under the standard warranty.

7.0 Maintenance

The oxygen generator requires little maintenance. Use the following chart as a guide to perform preventive maintenance at the required intervals.

Interval	Maintenance
Every two weeks	Clean gross particle filter. (Refer to Section 7.1 — Cleaning the Gross Particle Filter.)
Every month	Make sure product oxygen remains within specifications in Appendix A of this instruction manual.* Clean enclosure. (Refer to Section 7.2 — Cleaning the Enclosure.)
Every month	Check performance of solenoid valves. Rebuild or replace, as necessary.
* If product oxygen does not meet specifications, refer to Section 8.0 — Troubleshooting.	

Table 7.1 – Maintenance Chart

7.1 Cleaning the Gross Particle Filter

Clean the gross particle filter on the right side of the oxygen generator enclosure (See Figure 4.1) every two weeks, or more frequently if site conditions warrant. A clean filter allows the unit to cool properly.

Use the following procedure to clean the gross particle filter:

- 1) Shut down the oxygen generator as described in Section 6.3 — Shutdown.
- 2) Disconnect the power cord from the electrical outlet.



Do not operate the unit without the gross particle filter in place.

- 3) Remove the filter, and insert the second filter provided with unit.
- 4) Connect the power cord to the electrical outlet.
- 5) Restart the unit as described in Section 6.1 — Start-up.
- 6) Wash the filter removed from the unit in a solution of soap and warm water.
- 7) Rinse the filter thoroughly and remove excess water with a soft, absorbent towel.

- 8) Allow the filter to dry, and then store it in a clean location. Alternate the clean filter with the filter on the unit each time you perform this procedure.

7.2 Cleaning the Enclosure



Only trained personnel may open the oxygen generator. To prevent electrical shock, shut down the oxygen generator and disconnect the main power supply before you clean the enclosure.

Use the following procedure to clean the enclosure:

- 1) Shut down the oxygen generator as described in Section 6.3 — Shutdown.
- 2) Disconnect the power cord from the electrical outlet.
- 3) Use a dry, lint-free cloth on the enclosure, taking care to wipe the enclosure clean.



Dry cloth clean only. Do not apply liquid directly to the enclosure or use any petroleum-based solvents or cleaning agents.

7.3 Solenoid Valves

Check the performance of solenoid valves once every month. Rebuild or replace the solenoid valves as necessary (Refer to Section 8 – ‘Troubleshooting’ for some possible faulty valve scenarios). The typical preventive maintenance interval for the solenoid valves is 30,000 hours. Please refer to the table below to order the correct rebuild kit for the valves:

Model	Item	Rebuild Kit Part No.
Topaz	Feed & Waste Valves	VA034-1
Topaz	Equalization Valve	VA450-1
Topaz+	Feed & Waste Valves	VA034-1
Topaz+	Equalization Valve	Replace the assembly – VA003-9
Topaz Ultra	Feed & Waste Valves	VA034-1
Topaz Ultra	Equalization Valve	VA048-1

Table 7.2 – Rebuild Kits for Solenoid Valves

7.4 Air Compressor

The typical preventive maintenance interval for the air compressor is 15,000 hours. Rebuild the air compressor, if applicable, after 15,000 hours. If the air compressor for the unit you purchased does not come with a rebuild kit, replace the air compressor if the maximum cycle pressure starts to go below 179 kPa (26 psig).

Problem	Probable Cause	Solution
Unit does not operate.	No electrical power to unit.	Make sure power cord connects to electrical outlet and that electrical outlet receives power.
	Circuit breaker on I/O power switch tripped.	Reset the circuit breaker and set I/O power switch to <i>I</i> to restart unit.
	Blown fuse	Replace the fuse provided in 240 VAC units.
	Faulty electrical connections.	Disconnect main power supply, remove enclosure, and make sure all electrical connections, connect securely.
	Defective I/O power switch.	Replace I/O power switch.
Unit stops unexpectedly.	No electrical power to unit.	Make sure power cord connects to electrical outlet and that electrical outlet receives power.
	Circuit breaker on I/O power switch tripped.	Reset the circuit breakers and set I/O power switch to <i>I</i> to restart unit. If circuit breaker immediately trips again, check the wiring for any short circuit. Also, check I/O power switch, circuit board, capacitor, and air compressor. Replace all defective components.
Air compressor stops unexpectedly or does not operate when cooling fan operates.	Restricted air flow to air compressor.	Clean gross particle filter or remove obstruction.
	Thermal shutdown activated on air compressor.	Allow air compressor to cool, then restart unit.
	Faulty electrical connections.	Disconnect main power supply, remove enclosure, and make sure all electrical connections, including air compressor leads, connect securely.
	Improper power voltage.	Make sure power meets specifications in Appendix A of this instruction manual.
	Defective capacitor.	Replace capacitor.
	Defective air compressor.	Rebuild or replace air compressor (as applicable).

Unit operates, but air does not circulate into unit.	Faulty electrical connections to cooling fan.	Disconnect main power supply, remove enclosure, and make sure all electrical connections, including cooling fan leads, connect securely.
	Defective cooling fan.	Replace cooling fan.
Purity of product oxygen does not remain within specification in Appendix A of this instruction manual.	Leak in unit.	Pressurize unit, set I/O power switch to O, and disconnect power supply. Remove enclosure and make sure tubing remains connected to fittings. Use an oxygen-compatible leak-detecting solution to check all hoses, tubing, and fittings in unit. Most leaks are audible when area is quiet. Repair leaks and replace hoses or tubing as necessary.
	Obstructed exhaust muffler.	Replace exhaust muffler.
	Defective solenoid valve(s).	Repair or replace solenoid valve(s).
	Excess temperature inside enclosure due to inadequate ventilation outside enclosure, high ambient temperature, dirty gross particle filter, blocked air intake, or defective cooling fan.	Provide proper ventilation, make sure ambient temperature does not exceed specification in Appendix A of this instruction manual, clean filter, remove obstruction, or replace cooling fan.
	Defective or worn air compressor.	If maximum cycle pressure is below 179 kPa (26 psig), replace air compressor.
	Defective circuit board.	Replace circuit board.
Flowmeter fluctuates or flow rate of product oxygen changes unexpectedly.	Contaminated adsorbers.	Replace adsorbers.
	Leak in unit.	Pressurize unit, set I/O power switch to O, and disconnect power supply. Remove enclosure and make sure tubing remains connected to fittings. Use soapy water to check all hoses, tubing, and fittings in unit. Most leaks are audible when area is quiet. Repair leaks and replace hoses or tubing as necessary.

	Improperly set or defective pressure regulator.	Check regulator setting or replace defective regulator.
	Defective solenoid valve(s).	Repair or replace solenoid valve(s).
	Defective air compressor.	Replace air compressor.
	Defective circuit board.	Replace circuit board.
Unit operates, but I/O power switch does not illuminate.	Defective I/O power switch.	Replace I/O power switch.
Pressure of product oxygen changes unexpectedly.	Leak in unit.	Pressurize unit, set I/O power switch to O, and disconnect main power supply. Remove enclosure and make sure tubing remains connected to fittings. Use soapy water to check all hoses, tubing, and fittings in unit. Most leaks are audible when area is quiet. Repair leaks as necessary.
	Improperly set or defective pressure regulator.	Check regulator setting or replace defective regulator.
	Relief valves release.	Refer to “Popping’ sound indicates release of relief valves” problem in troubleshooting chart.
	Defective air compressor.	Rebuild or replace air compressor (as applicable).
“Popping” sound indicates release of relief valves.	Obstructed exhaust muffler.	Replace exhaust muffler.
	Improperly set or defective pressure regulator.	Check regulator setting or replace defective regulator.
	Defective solenoid valve(s).	Repair or replace solenoid valve(s).
	Defective circuit board.	Replace circuit board.
	Contaminated adsorbers.	Replace adsorbers.
Chattering or buzzing noise from solenoid valve(s).	Low voltage to valve(s).	Make sure electrical power remains within specification in Appendix A of this manual. If power at inlet to unit is correct but is low at valve(s), contact AirSep.
	Defective or worn solenoid valve(s).	Repair or replace solenoid valve(s).

A Appendix: Technical Data

Specifications

Data in this section refer to the Topaz, Topaz+ and Topaz Ultra oxygen generators. Consult your sales representative to determine whether your oxygen generator requires modifications for your application.



Provide proper voltage from a grounded outlet to the oxygen generator. Main power supply voltage fluctuation must not exceed 10% of the nominal supply voltage.

Topaz

Oxygen Flow:	0.31 Nm ³ /hr* 12 SCF/hr** (6 LPM on the flowmeter)
Standard Oxygen Pressure:	9 psig (62 kPa)
Oxygen Purity:	93% ± 3% at specified oxygen o/p
Dew point:	-73°C (-100°F)
Sound Level:	55dB at 1 meter (open field cond.)
Dimensions:	48 x 25 x 69 cm (W x D x H) 19 x 10 x 27 in. (W x D x H)
Weight:	21 kg (46 lb)
Power Requirements:	100 V~± 10%, 50 or 60 Hz, 5.5 A 120 V~± 10%, 60 Hz, 5.0 A 240 V~± 10%, 50 or 60 Hz, 2.5 A (All the above are Single Phase)
Ventilation:	Do not install adjacent to heat source and allow a minimum of six inches around unit to provide adequate airflow
Ambient temperature range:	40°C (104°F) maximum 4°C (40°F) minimum
Other Specifications:	
Pollution Degree	2
Installation Category	II
Maximum altitude above sea level:	2,000 m (6,562 ft)

* Nm³ (normal cubic meters) gas measured at 1 atmosphere and 0°C.

** SCF (standard cubic foot) gas measured at 1 atmosphere and 70°F

Topaz+

Oxygen Flow:	0.44 Nm ³ /hr* 17 SCF/hr** (8 LPM on the flowmeter)
Standard Oxygen Pressure:	20 psig (138 kPa)
Oxygen Purity:	93% ± 3% at specified oxygen o/p
Dew point:	-73°C (-100°F)
Sound Level:	55dB at 1 meter (open field cond.)
Dimensions:	48 x 25 x 69 cm (W x D x H) 19 x 10 x 27 in. (W x D x H)
Weight:	21 kg (46 lb)
Power Requirements:	120 V~± 10%, 60 Hz, 5.0 A 240 V~± 10%, 50 or 60 Hz, 2.5 A (All the above are Single Phase)
Ventilation:	Do not install adjacent to heat source and allow a minimum of six inches around unit to provide adequate airflow
Ambient temperature range:	40°C (104°F) maximum 4°C (40°F) minimum

Other Specifications:

Pollution Degree	2
Installation Category	II
Maximum altitude above sea level:	2,000 m (6,562 ft)

* Nm³ (normal cubic meters) gas measured at 1 atmosphere and 0°C.

** SCF (standard cubic foot) gas measured at 1 atmosphere and 70°F

Topaz Ultra

Oxygen Flow:	0.54 Nm ³ /hr* 21 SCF/hr** (10 LPM on the flowmeter)
Standard Oxygen Pressure:	20 psig (138 kPa)
Oxygen Purity:	93% ± 3% at specified oxygen o/p
Dew point:	-73°C (-100°F)
Sound Level:	55dB at 1 meter (open field cond.)
Dimensions:	48 x 25 x 69 cm (W x D x H) 19 x 10 x 27 in. (W x D x H)
Weight:	21 kg (46 lb)
Power Requirements:	120 V~± 10%, 60 Hz, 6.0 A 240 V~± 10%, 50 Hz, 3.0 A (All the above are Single Phase)
Ventilation:	Do not install adjacent to heat source and allow a minimum of six inches around unit to provide adequate airflow
Ambient temperature range:	40°C (104°F) maximum 4°C (40°F) minimum

Other Specifications:

Pollution Degree	2
Installation Category	II
Maximum altitude above sea level:	2,000 m (6,562 ft)

* Nm³ (normal cubic meters) gas measured at 1 atmosphere and 0°C.

** SCF (standard cubic foot) gas measured at 1 atmosphere and 70°F

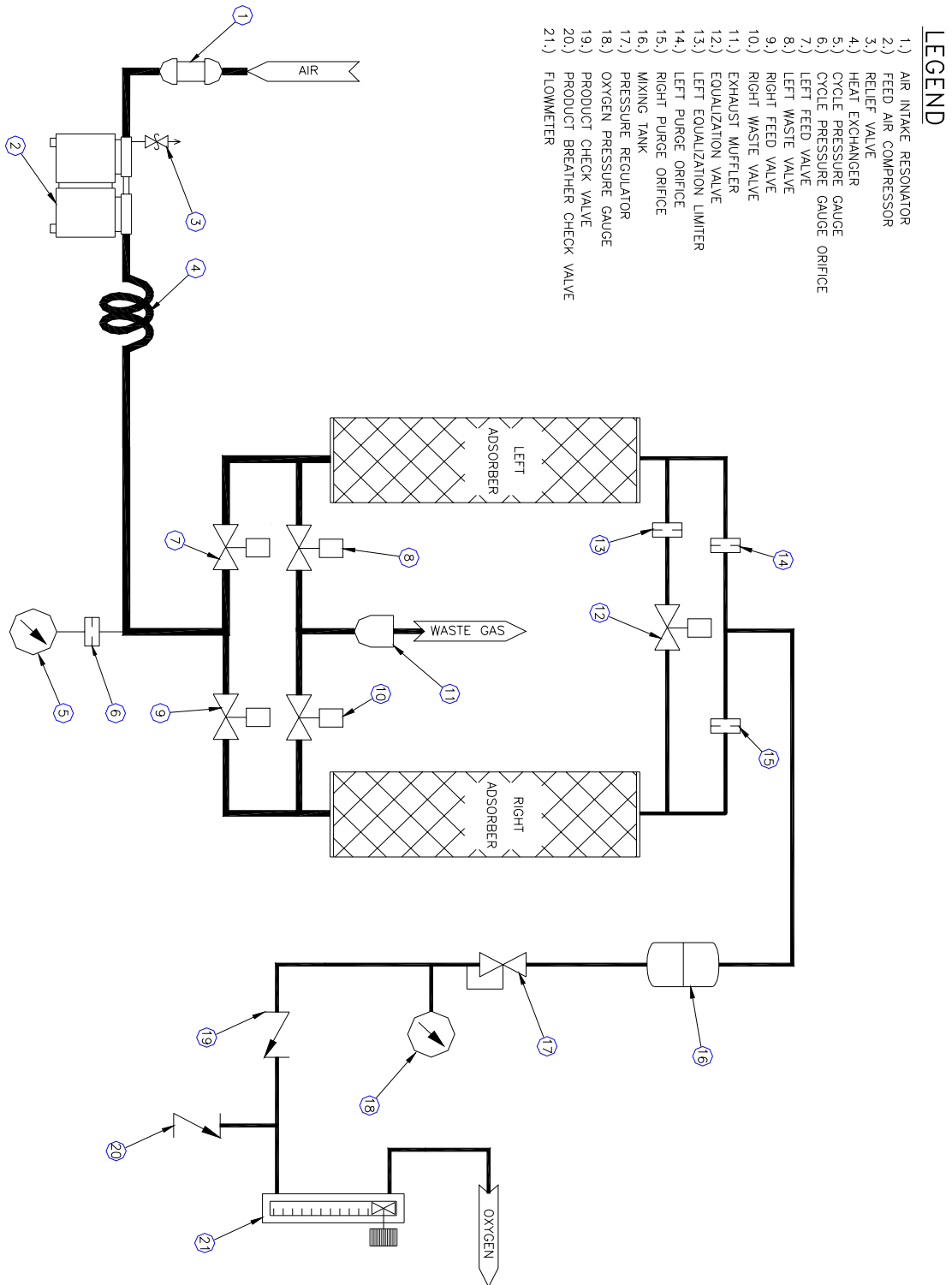

Figure A.1 - Flow Schematic - Topaz

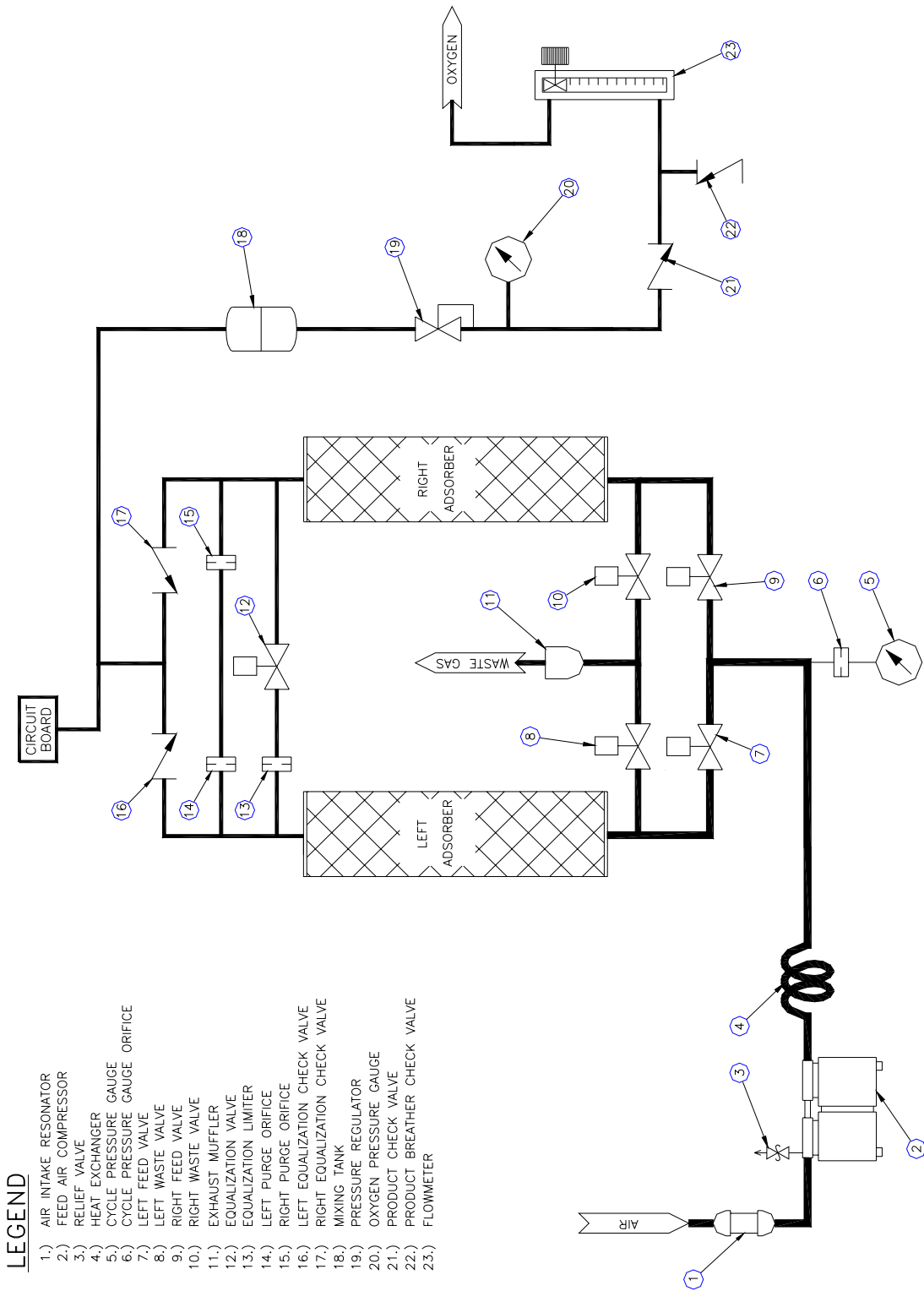

Figure A.2 – Flow Schematic – Topaz+

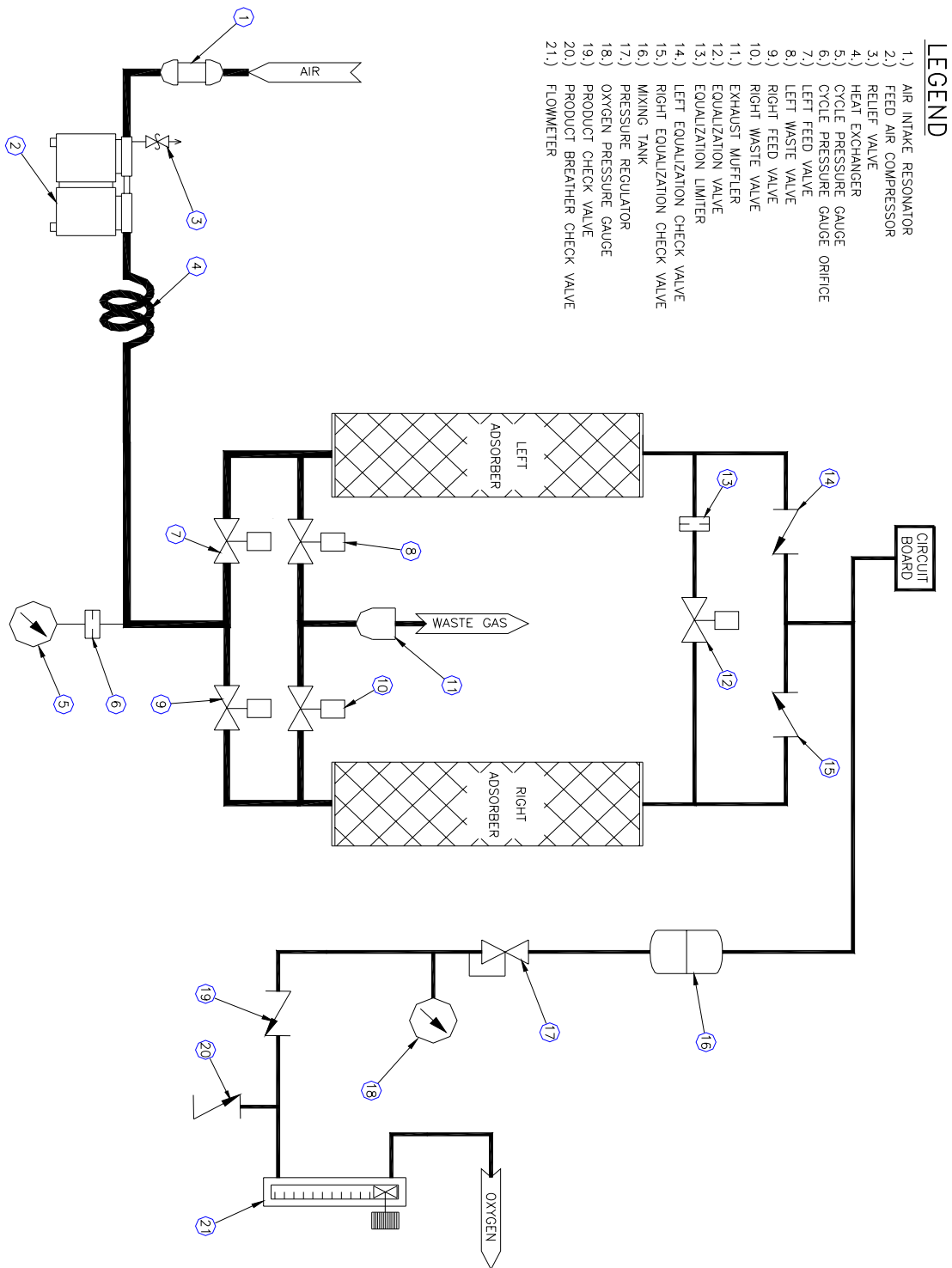

Figure A.3 – Flow Schematic – Topaz Ultra

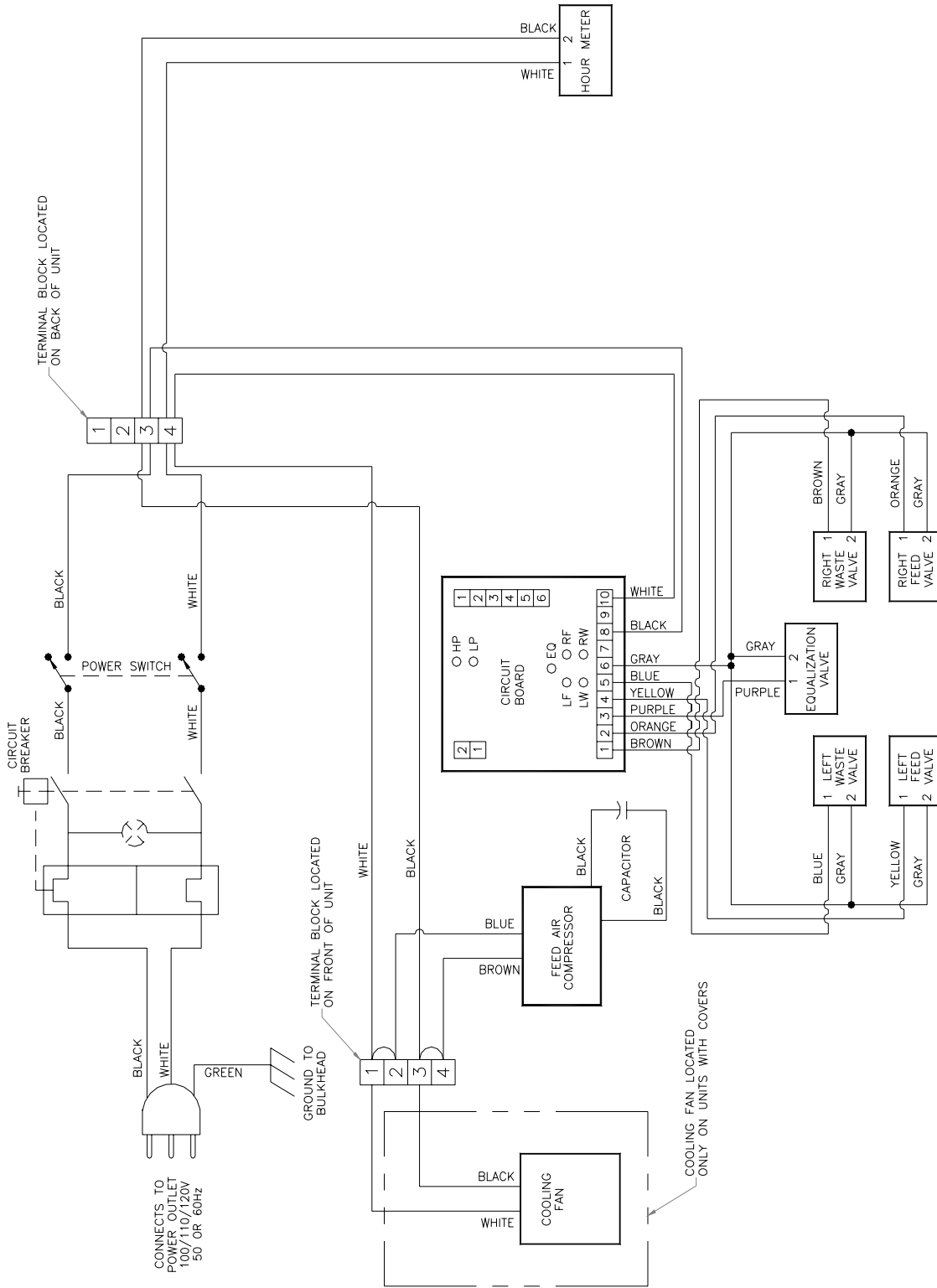

Figure A.4 – 100/110/120 V, 50 or 60 Hz Electrical Schematic

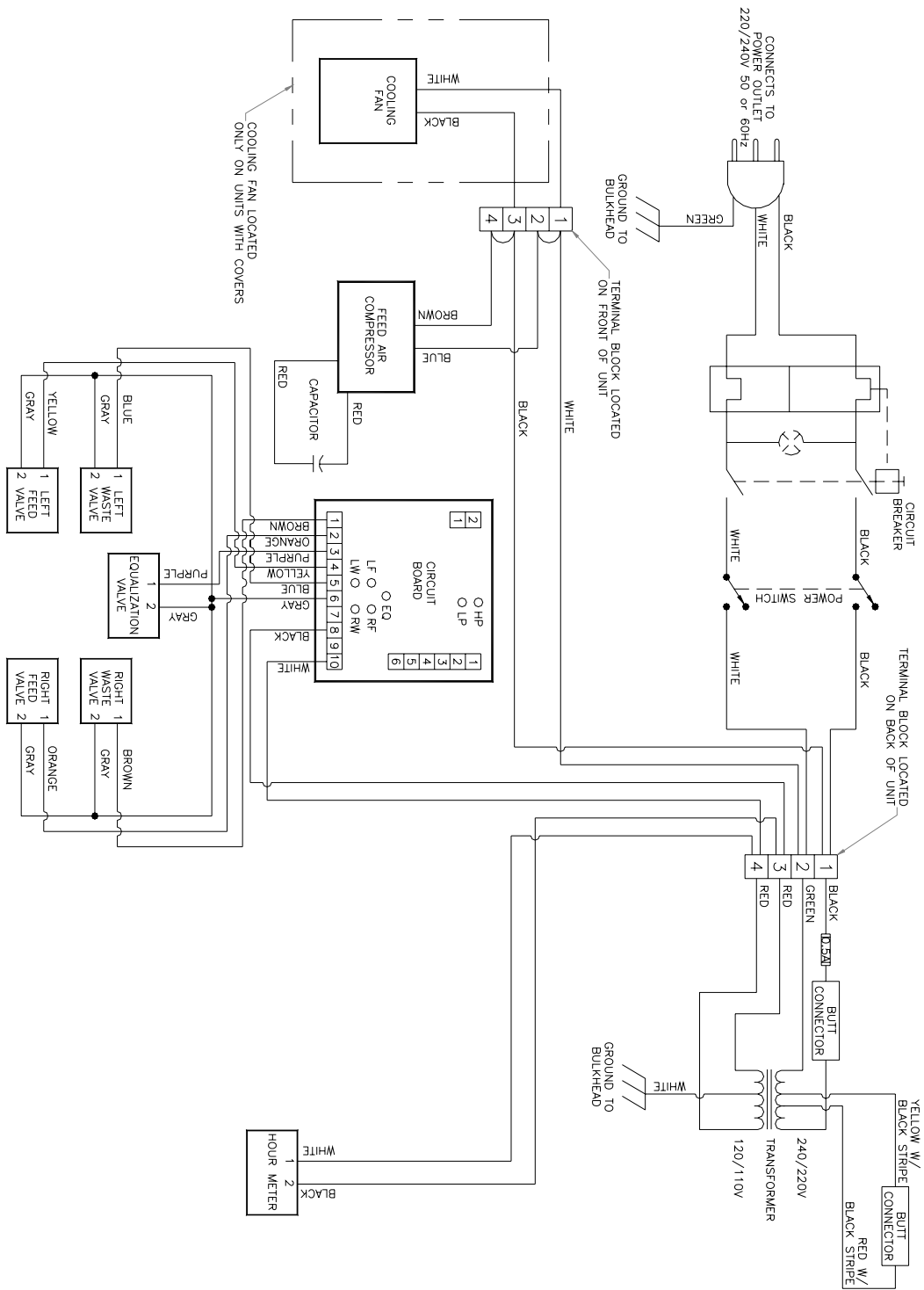

Figure A.5 – 240 V, 50 or 60 Hz Electrical Schematic

B Appendix: Warranty>Returns

Product Warranty

AirSep Corporation (“AirSep”) warrants to the party purchasing from AirSep (the “original purchaser”) the PSA oxygen generator (Topaz/Topaz+/Topaz Ultra) to be free from defect in parts and workmanship for one year from the date of start-up, not to exceed eighteen (18) months from the date of shipment to the original purchaser, under normal use, maintenance and operation*. TO THE EXTENT PERMITTED UNDER APPLICABLE LAW, ALL WARRANTIES WITH RESPECT TO SUCH UNIT SHALL ONLY EXTEND TO AND BE FOR THE BENEFIT OF THE ORIGINAL PURCHASER AND SHALL NOT BE ASSIGNABLE TO, EXTEND TO OR BE FOR THE BENEFIT OF ANY OTHER PARTY. AirSep’s obligations under this warranty are limited, at AirSep’s option, to the repair, replacement or refunding the purchase price of any such unit of equipment (or part thereof) found by AirSep to be defective in parts or workmanship; provided, however, that AirSep shall have no obligation hereunder with respect to a defective part unless it receives written notice of such defect prior to the expiration of the applicable warranty period as referenced above.

Each unit of equipment for which a warranty claim is asserted shall, at the request of AirSep, be returned on a prepaid basis with proof of purchase date to the AirSep factory specified by AirSep at the expense of the original purchaser. Replacement parts shall be warranted as stated above for the unexpired portion of the original warranty. This warranty does not extend to any unit or part subjected to misuse (at AirSep’s sole determination), accident, improper maintenance or application, or which has been repaired or altered outside of the AirSep factory without the express prior written authorization of AirSep.

Notwithstanding anything to the contrary contained herein, during the applicable warranty period, as specified above, AirSep will pay the cost of return freight charges to the original purchaser, provided an authorized AirSep representative approved return of the unit or parts, for any equipment found by AirSep to be defective. For warranty repairs performed during the first 90 days from the date of invoice, AirSep will pay freight both ways. After the applicable parts warranty period has expired, the original purchaser is responsible for freight both ways.

* Please refer to the appropriate product documentation for applicable installation and operating requirements.

Limits of Liability

THE FOREGOING WARRANTY IS THE ONLY WARRANTY MADE BY AIRSEP WITH RESPECT TO THE EQUIPMENT (OR ANY PART THEREOF) AND IS IN LIEU OF ANY OTHER WARRANTY, EXPRESSED OR IMPLIED, IN FACT OR IN LAW, INCLUDING WITHOUT LIMITATION ANY WARRANTIES OF MERCHANTABILITY OR FITNESS FOR ANY PARTICULAR PURPOSE. IT IS EXPRESSLY UNDERSTOOD THAT THE SOLE AND EXCLUSIVE REMEDY FOR ANY DEFECT IN PARTS OR WORKMANSHIP IS LIMITED TO ENFORCEMENT OF AIRSEP'S OBLIGATIONS AS SET FORTH ABOVE, AND AIRSEP SHALL NOT BE LIABLE TO ORIGINAL PURCHASER OR ANY OTHER PARTY FOR LOSS OF USE OF THE EQUIPMENT, LOST PROFITS OR FOR ANY OTHER SPECIAL, INDIRECT, INCIDENTAL, OR CONSEQUENTIAL DAMAGES (EVEN IF AIRSEP HAS BEEN ADVISED OF THE POSSIBILITY OF SUCH DAMAGES).



AirSep oxygen generators are sold for use in industrial applications only. Contact AirSep or an authorized AirSep representative before you use this unit for any medical application.

Returning the Oxygen Generator or a Component for Service

Follow the procedure below to return the oxygen generator or a component for service or credit.

- 1) Obtain a Return Goods Authorization (RGA) number from the AirSep Commercial Products Service Department. Before you contact AirSep, have the following information readily available (noted on the ownership data page in the front of this instruction manual):
 - generator model
 - serial number
 - hours of use (see hour meter inside enclosure)
 - invoice date



AirSep issues no credit for any warranted item until you present the model number, serial number, and invoice date of the oxygen generator.

- 2) Write the RGA number clearly on the outside of the shipping container.



AirSep accepts no item(s) for service or credit unless prior written authorization was issued by AirSep.

- 3) Use the original packaging material to return item(s). Pack merchandise for a safe return. AirSep assumes no responsibility for damage that occurs in transit. Any damage to the oxygen generator or a component because of failure to follow this procedure is the sole responsibility of the customer.



Return item(s) on a freight-prepaid basis only.

C Appendix: Parts List

Use the following parts list to order parts for your oxygen generator. To order, please contact the AirSep Commercial Products Service Department. Refer to Section 8.0 — Troubleshooting for information about contacting the Commercial Products Service Department. If the parts list does not include the part you require, please provide a precise description of the part when you contact the Commercial Products Service Department.

Topaz (100 VAC or 120 VAC)

Item	Qty.	Part#
Emergency Spares		
Capacitor, 15uF Metal Case, 370V	1	CC006-3
Fan, 115VAC, 50/60HZ, 3001	1	FN001-1
Circuit Board, 120V, 17.6, SEC	1	CB004-1
Mount, Sandwich, 30 LB, 1/4-20 Threads	4	MO007-1
Regulator, 0-10 PSI, w/Holes Non-Relieving, Norgren	1	RG022-1
Muffler, 1/4" MPT, Norgren	1	MU034-1
Flowmeter, 6 LPM	1	FM080-1
Foam, Acoustic, Muffler	1	FO003-1
Foam, Filter, 4" X 4" X 1/2" Thk 15 PPI	1	FO015-1
Heat Exchanger	1	HX002-2
Hour Meter, LCD, 100-270VAC, 50/60 HZ	1	HM009-1
Beds Assy, 3" DIA X 16" LG	1	BE036-2
Switch, Rocker, Green	1	SW004-1
Supplemental Equipment		
Analyzer, Maxtec, Max O2 plus	1	AN005-1
Analyzer, O2, Maxtec, Handi Handheld	1	AN021-1
12,000 Hours		
Compressor, Thomas, 2660CE32, 120/60, PVC Tubes, Connectors	1	CO240-1
Compressor Assy, 100V 50HZ	1	CO076-5
Compressor, Kit, Compression, 2660, Trigon	1	CO012-11
30,000 Hours		
Valve, Solenoid, 1/4", 100VDC *AU11*	4	VA001-1
Valve, Solenoid Rebuilt Kit, Feed/Waste, 316372	4	VA034-1
Valve, Solenoid, Floater 100 VDC EQ, HV272136-1, ASCO	1	VA003-6
Valve, Kit, Rebuilt for VA003-6 318-356 **ASCO**	1	VA450-1
Valve, Solenoid, 1/8" FPT, 120V 60HZ, SC8256B045V, 0.19CV**AU11*	1	VA495-3

Topaz (240 VAC)

Item	Qty.	Part#
Emergency Spares		
Capacitor, 10uF Metal Case, 450V	1	CC006-6
Fan, 230VAC	1	FN001-2
Circuit Board, 120V, 17.6, SEC	1	CB004-1
Mount, Sandwich, 30 LB, 1/4-20 Threads	4	MO007-1
Regulator, 0-10 PSI, w/Holes Non-Relieving, Norgren	1	RG022-1
Muffler, 1/4" MPT, Norgren	1	MU034-1
Flowmeter, 6 LPM	1	FM080-1
Foam, Acoustic, Muffler	1	FO003-1
Foam, Filter, 4" X 4" X 1/2" Thk 15 PPI	1	FO015-1
Heat Exchanger	1	HX002-2
Hour Meter, LCD, 100-270VAC, 50/60 HZ	1	HM009-1
Beds Assy, 3"DIA X 16"LG	1	BE036-2
Switch, Rocker, Green	1	SW004-1
Supplemental Equipment		
Analyzer, Maxtec, Max O2 plus	1	AN005-1
Analyzer, O2, Maxtec, Handi Handheld	1	AN021-1
12,000 Hours		
Compressor Assy, 220/60	1	CO076-3
Compressor Assy, 220/50	1	CO076-2
Compressor, Kit, Compression, 2660, Trigon	1	CO012-11
30,000 Hours		
Valve, Solenoid, 1/4", 100VDC *AU1I*	4	VA001-1
Valve, Solenoid Rebuilt Kit, Feed/Waste, 316372	4	VA034-1
Valve, Solenoid, 1/8", 100 VDC, ASCO, EQ, HV238-915-2, 100V	1	VA003-1
Valve, Kit, Rebuilt for VA003-6 318-356 **ASCO**	1	VA450-1
Valve, Solenoid, 1/8" FPT, 120V 60HZ, SC8256B045V, 0.19CV**AU1I*	1	VA495-3

Topaz+ (120 VAC)

Item	Qty.	Part#
Emergency Spares		
Capacitor, 15uF Metal Case, 370V	1	CC006-3
Circuit Breaker, 8 AMP	1	CR001-1
Fan, 115VAC, 50/60HZ, 3001	1	FN001-1
Circuit Board, Master, Assembly, 8 Liter, 120V	1	CB068-3
Mount, Sandwich, 30 lb, 1/4-20 Threads	4	MO007-1
Regulator, 1/4" FPT, Norgren, 100 psig	1	RG088-1
Muffler, 1/4" MPT, Norgren	1	MU034-1
Flowmeter, 8 LPM	1	FM080-2
Foam, Acoustic, Muffler	1	FO003-1
Foam, Filter, 4" X 4" X 1/2" THK 15 PPI	1	FO015-1
Heat Exchanger	1	HX002-2
Hour meter, LCD, 100-270VAC, 50/60 HZ	1	HM009-1
Beds, 8L, Assy, 18" long	1	BE176-1
Switch, Rocker, Green	1	SW004-1
Tank, 8L, Mixing, Assy	1	TA110-1
Valve, Check, 1/4" barb X 1/4" barb MPC, 3001, MPCA975	2	VA006-1
Valve, Check, Acrylic, Hose Barb	2	VA142-3
Gauge, Dual Scale, 1-1/2" 0-30 psi, 1/8" MPT, w/CLP	1	GA001-5
Supplemental Equipment		
Analyzer, Maxtec, Max O2 Plus	1	AN005-1
Analyzer, O2, Maxtec, Handi Handheld	1	AN021-1
12,000 Hours		
Compressor, Assy, 120/60	1	CO262-1
Compressor, Kit, Compression, 2660, Trigon	1	CO012-11
30,000 Hours		
Valve, Solenoid, 1/4", 100VDC *AU11*	1	VA001-1
Valve, Solenoid Rebuild Kit, Feed/Waste, 316372	4	VA034-1
Valve, Solenoid, Plastic, 100 VDC, Equalization	1	VA003-9

Topaz+ (240 VAC)

Item	Qty.	Part#
Emergency Spares		
Capacitor, 10uF Metal Case, 450V	1	CC006-6
Circuit Breaker, 2.5 AMP	1	CR001-5
Fan, 230VAC, 50 HZ	1	FN001-2
Circuit Board, Master, Assembly, 8 Liter, 120V	1	CB068-3
Mount, Sandwich, 30 lb, 1/4-20 Threads	4	MO007-1
Regulator, 1/4" FPT, Norgren, 100 psig	1	RG088-1
Muffler, 1/4"MPT, Norgren	1	MU034-1
Flowmeter, 8 LPM	1	FM080-2
Foam, Acoustic, Muffler	1	FO003-1
Foam, Filter, 4" X 4" X 1/2"THK 15 PPI	1	FO015-1
Heat Exchanger	1	HX002-2
Hour meter, LCD, 100-270VAC, 50/60 HZ	1	HM009-1
Beds, 8L, Assy, 18" long	1	BE176-1
Switch, Rocker, Green	1	SW004-1
Tank, 8L, Mixing, Assy	1	TA110-1
Valve, Check, 1/4"barb X1/4"barb MPC, 3001, MPCA975	2	VA006-1
Valve, Check, Acrylic, Hose Barb	2	VA142-3
Gauge, Dual Scale, 1-1/2" 0-30 psi, 1/8"MPT, w/CLP	1	GA001-5
Supplemental Equipment		
Analyzer, Maxtec, Max O2 Plus	1	AN005-1
Analyzer, O2, Maxtec, Handi Handheld	1	AN021-1
12,000 Hours		
Compressor, Assy, 220 VAC	1	CO262-2
Compressor, Kit, Compression, 2660, Trigon	1	CO012-11
30,000 Hours		
Valve, Solenoid, 1/4", 100VDC *AU11*	1	VA001-1
Valve, Solenoid Rebuild Kit, Feed/Waste, 316372	4	VA034-1
Valve, Solenoid, Plastic, 100 VDC, Equalization	1	VA003-9

Topaz Ultra (120 VAC)

Item	Qty.	Part#
Emergency Spares		
Circuit Board, Master Assembly, 10L,120V	1	CB068-9
Capacitor, Metal Case, 20 uF, 370VAC	1	CC006-8
Heat Exchanger	1	HX002-2
Mount,Sandwich,30 lb,1/4-20 Threads	4	MO007-1
Fan, NMB	1	FN022-1
Foam,Filter,4" X 4" X 1/2"Thk 15 PPI	1	FO015-1
Bed Assembly	1	BE303-1
Flowmeter, 10 LPM	1	FM080-3
Gauge, Dual Scale,1-1/2" 0-30 PSI,1/8"MPT,w/CLP	1	GA001-5
Gauge, Dual Scale,1-1/2",0-100 PSI 1/8"MPT,w/MNTG CLP	1	GA001-2
Hour Meter,LCD,100-270VAC, 50/60 HZ	1	HM009-1
Foam, Acoustic, Muffler	1	FO003-1
Muffler,1/4"MPT,Norgren	1	MU034-1
Regulator, 1/4" FPT, Norgren, 100 psig	1	RG088-1
Switch, Rocker, Green	1	SW004-1
Mixing Tank	1	TA149-1
Valve Block, Non-Anodized, SS Plugs	1	VA290-1
Circuit Breaker,8 Amps	1	CR001-1
Supplemental Equipment		
Analyzer, Maxtec, Max O2 Plus	1	AN005-1
Analyzer, O2, Maxtec, Handi Handheld	1	AN021-1
12,000 Hours		
Compressor,Thomas,2660CE50, 120/60,PVC Tubes, Connectors	1	CO305-1
Compressor, Kit, Compression, 2660, Trigon	1	CO012-11
30,000 Hours		
Valve,Solenoid,1/8",100VDC ASCO,EQ,HV238-915-2 100V	1	VA003-1
Valve, Rebuild Kit for VA003-1 MEDSERV,316375 **AU1**	1	VA048-1
Valve, Solenoid Rebuild Kit,Feed/Waste,316372	4	VA034-1

Topaz Ultra (240 VAC)

Item	Qty.	Part#
Emergency Spares		
Circuit Board, Master Assembly, 10L,120V	1	CB068-9
Capacitor, Metal Case, 20 uF, 370VAC	1	CC006-8
Heat Exchanger	1	HX002-2
Mount,Sandwich,30 lb,1/4-20 Threads	4	MO007-1
Fan, NMB, Dual 6, 220V	1	FN022-2
Foam,Filter,4" X 4" X 1/2"Thk 15 PPI	1	FO015-1
Fuse,0.5 Amp	1	FU024-1
Bed Assembly	1	BE303-1
Flowmeter, 10 LPM	1	FM080-3
Gauge, Dual Scale,1-1/2" 0-30 PSI,1/8"MPT,w/CLP	1	GA001-5
Gauge, Dual Scale,1-1/2",0-100 PSI 1/8"MPT,w/MNTG CLP	1	GA001-2
Hour Meter,LCD,100-270VAC, 50/60 HZ	1	HM009-1
Foam, Acoustic, Muffler	1	FO003-1
Muffler,1/4"MPT,Norgren	1	MU034-1
Regulator, 1/4" FPT, Norgren, 100 psig	1	RG088-1
Switch, Rocker, Green	1	SW004-1
Mixing Tank	1	TA149-1
Valve Block, Non-Anodized, SS Plugs	1	VA290-1
Transformer,220/110,N-68X	1	TR026-1
Circuit Breaker,4 Amps	1	CR001-6
Supplemental Equipment		
Analyzer, Maxtec, Max O2 Plus	1	AN005-1
Analyzer, O2, Maxtec, Handi Handheld	1	AN021-1
12,000 Hours		
Compressor,Thomas,2660CHI56, 220/50,PVC Tubes, Connectors	1	CO337-1
Compressor, Kit, Compression, 2660, Trigon	1	CO012-11
30,000 Hours		
Valve,Solenoid,1/8",100VDC ASCO,EQ,HV238-915-2 100V	1	VA003-1
Valve, Rebuild Kit for VA003-1 MEDSERV,316375 **AU11**	1	VA048-1
Valve, Solenoid Rebuild Kit,Feed/Waste,316372	4	VA034-1

D Appendix: Component Literature

Compressors

- Thomas Industries
2660 Series, Compressors
CE32, CG32, CHI37 and CHI42
[Exploded View and Parts List](#)
- Thomas Industries
2660 Series, Compressors
CE32, CG32, CHI37 and CHI42
[Wiring Diagram](#)
- Thomas Industries
2660 Series, Compressors
CE32, CG32, CHI37 and CHI42
[Troubleshooting Guide](#)
- Thomas Industries
2660 Series, Compressors
CE36
[Exploded View and Parts List](#)
- Thomas Industries
2660 Series, Compressors
CE36
[Wiring Diagram](#)
- Thomas Industries
2660 Series, Compressors
CE36
[Troubleshooting Guide](#)
- Thomas Industries
2660 Series, Compressors
CE50
[Exploded View and Parts List](#)
- Thomas Industries
2660 Series, Compressors
CE50
[Wiring Diagram](#)
- Thomas Industries
2660 Series, Compressors
CE50
[Troubleshooting Guide](#)

- Thomas Industries
2660 Series, Compressors
CHI56
[Exploded View and Parts List](#)
- Thomas Industries
2660 Series, Compressors
CHI56
[Wiring Diagram](#)
- Thomas Industries
2660 Series, Compressors
CHI56
[Troubleshooting Guide](#)

Regulator

- Norgren
R07 Regulator
General Purpose Regulators
[Installation and Adjustment Instructions](#)

Valves

- ASCO Valve Inc.
[Solenoid Valve Assembly Diagram](#)
- ASCO Valve Inc.
U8016 & US8016
Open-Frame Solenoids
[Installation and Maintenance Instructions](#)
- ASCO Valve Inc.
HV238915
Solenoid Valves, Dwg# 214639-107
[General Installation and Maintenance Instructions](#)
- ASCO Valve Inc.
8262 & 8263 Series
2-way, Direct Acting, Solenoid Valves
[Installation and Maintenance Instructions](#)
- ASCO Valve Inc.
8225 Series
2-way, Direct Acting, Solenoid Valves
[Installation and Maintenance Instructions](#)



**2660CE32-190, 2660CHI37-190, 2660CG32-190,
2660CHI42-190 & 2660CG36-190**

Compressor

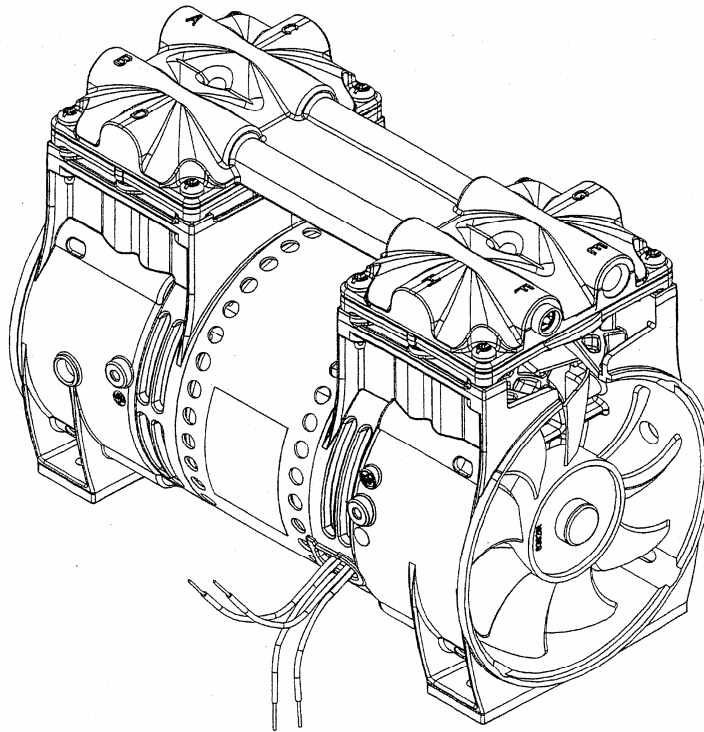

©2004 Thomas Industries, Sheboygan Inc.

FSM 0132 Revision D 11/04

Exploded View and Parts List

Exploded View of the Thomas 2660 Series Compressor

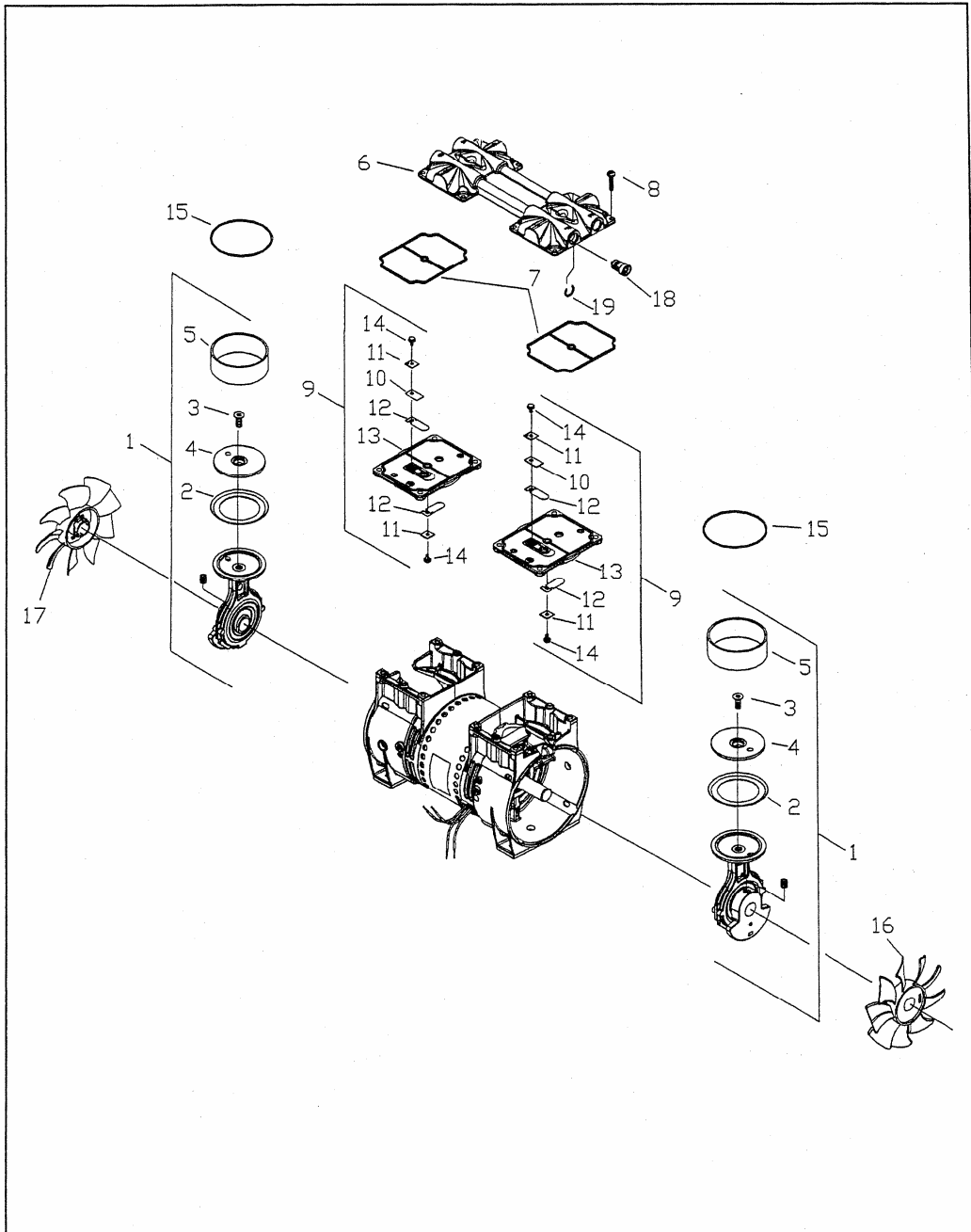

Field Service Parts List for Thomas 2660 Series Compressors

Item No.	Part No.	Qty. Per Asmby	Qty. Per Unit	Description
1*	See Chart	-	2	Connecting Rod, Eccentric & Bearing Assembly
2	624677	1	2	Piston Cup
3	625776	1	2	Screw - Piston Cup Retainer
4	626392	1	2	Piston Cup Retainer
5	618114	1	2	Cylinder Sleeve
6	662809	-	1	Head
7	623143	-	2	O-Ring - Head Gasket
8	625175	-	8	Screw - Head
9	621591	-	2	Valve Plate Assembly
10	617177	1	2	Valve Restraint
11	617562	2	4	Valve Keeper Strip
12	621485	2	4	Valve Flapper - Intake & Exhaust
13	621641	1	2	Valve Plate
14	625094	2	4	Screw - Valve Flapper
15	623137	-	2	O-Ring Valve Plate
16	638281	-	1	Fan - Gray
17	638282	-	1	Fan - Black
18	638701	-	1	Valve - Pressure Relief
19	623093	-	1	Retaining Clip - PRV

Connecting Rod, Eccentric & Bearing Assembly

Item	Part No.	Description	Qty
1*	666800	2660CE32-190 and 2660CG32-190	2
1*	666660	2660CHI37-190 Compressor	2
1*	666702	2660CHI42-190 Compressor	2
1*	666855	2669CG36-190 Compressor	2

Wiring Diagram

Use this wiring diagram to connect your compressor to the power source.

2660CE32-190

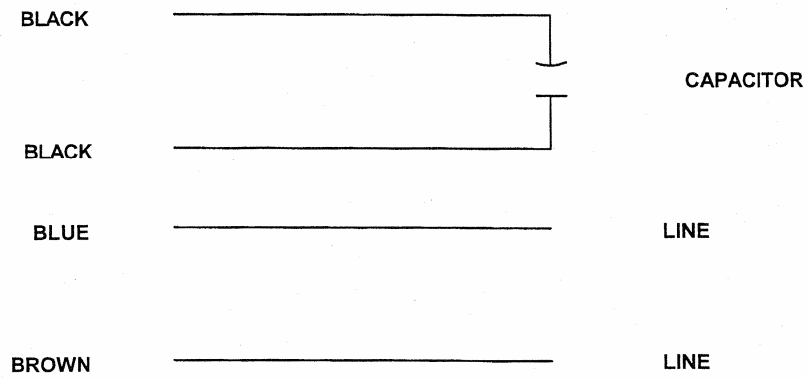

2660CHI37-190, 2660CHI42-190, 2660CG32-190 & 2660CG36-190

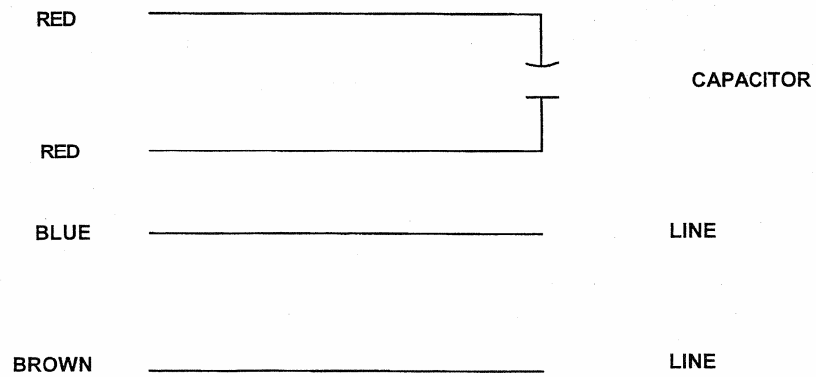

Troubleshooting Guide

If you are having a problem with your compressor, use this table to help determine the cause(s):

Low Flow	Low Pressure	Problem		Loud Unit	Possible Cause	Corrective Action
		Unit Will Not Start	Motor ^① Overheats			
			x		High voltage at compressor	Reduce voltage
x	x	x	x		Low voltage at compressor	Increase voltage
x	x			x	Damaged valves	Replace flapper valves
x	x			x	Debris in valves	Remove debris and check for valve damage
x	x			x	Damaged gaskets	Replace gaskets
x	x			x	Worn Cup	Replace connecting rod assembly or cup
x	x			x	Loose head screws	Tighten head screws
			x		Broken fan	Replace fan
		x	x	x	Bent motor shaft	Replace entire unit
		x	x		Damaged capacitor	Replace capacitor
x					Loose fittings	Tighten fittings
x			x		Insufficient ventilation in enclosure	Increase air circulation to enclosure
		x		x	Worn bearings	Replace eccentric and bearing assembly
				x	Loose rod clamping screw	Apply Loctite® 242 and retighten

① Thermal protector in motor will interrupt current when motor overheats.



2660CE35-190 & 2660CE36-190

Compressor

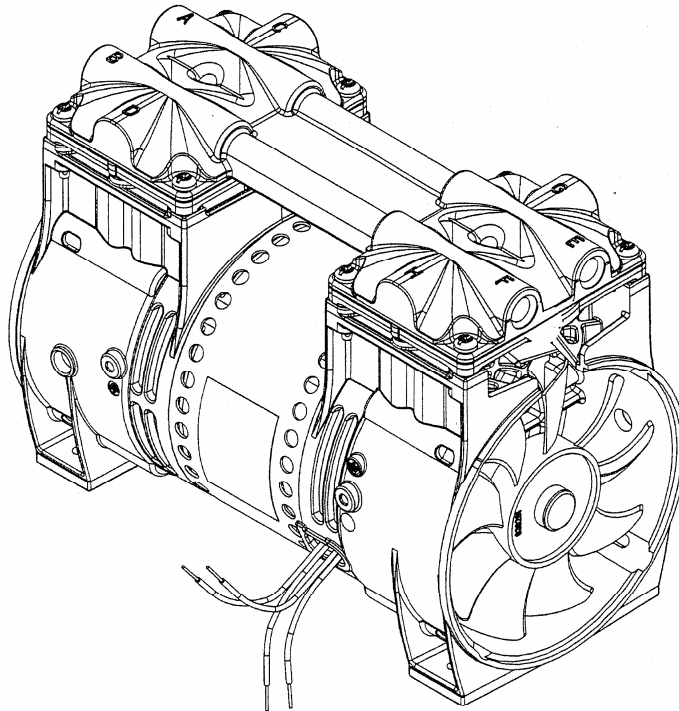

© 2003 Thomas Industries Sheboygan, Inc.

FSM 0166 Rev. A 07/04

Exploded View and Parts List

Exploded View of the Thomas 2660 Series Compressor

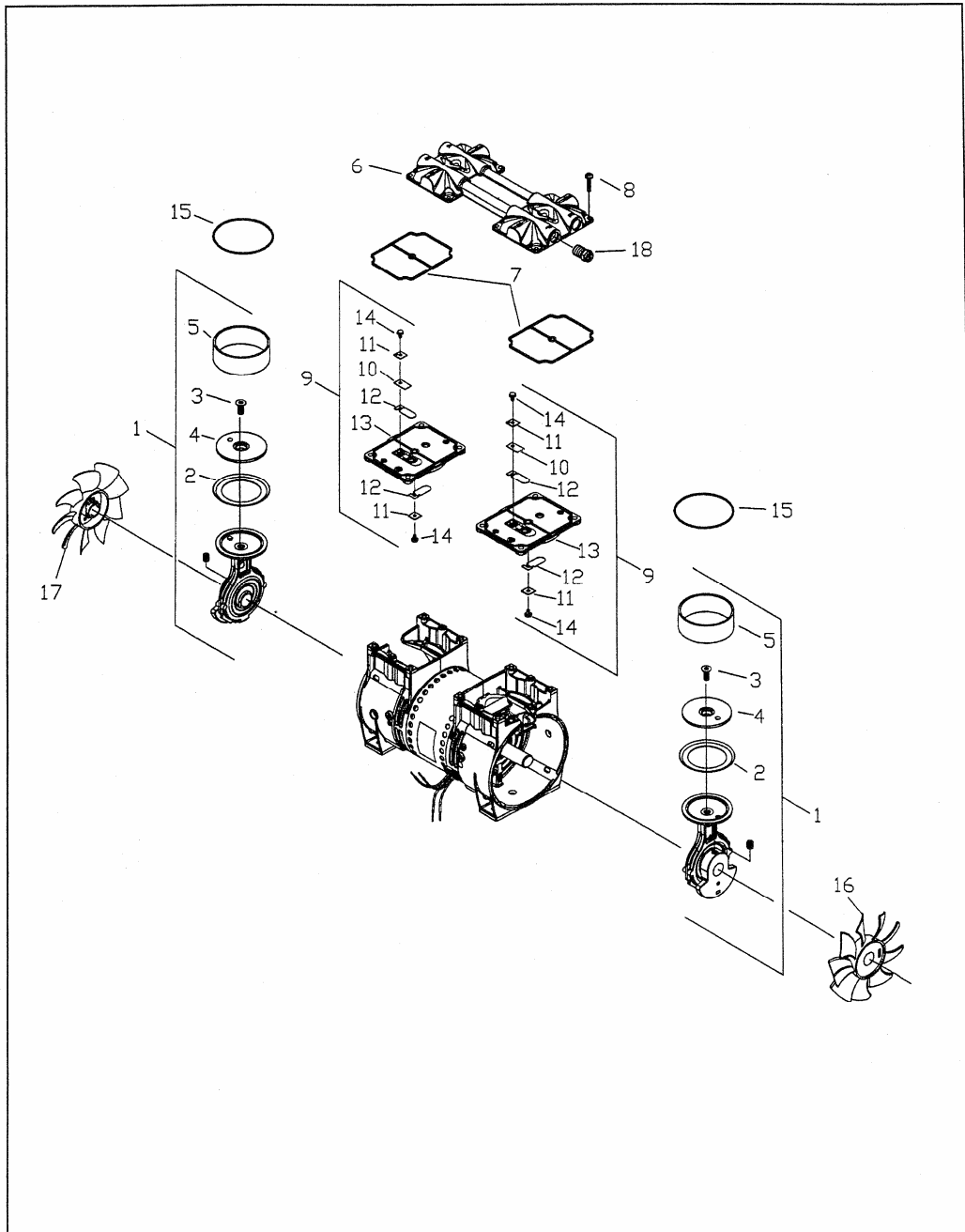

Field Service Parts List for Thomas 2660 Series Compressor

Item No.	Part No.	Qty. Per Asmbly	Qty. Per Unit	Description
1	See Chart	–	2	Connecting Rod, Eccentric & Bearing Assembly
2	614942	1	2	Piston Cup
3	625776	1	2	Screw - Piston Cup Retainer
4	626392	1	2	Piston Cup Retainer
5	618114	1	2	Cylinder Sleeve
6	610534	–	1	Head
7	623143	–	2	O-Ring - Head Gasket
8	625175	–	8	Screw - Head
9	621591	–	2	Valve Plate Assembly
10	617177	1	2	Valve Restraint
11	617562	2	4	Valve Keeper Strip
12	621485	2	4	Valve Flapper - Intake & Exhaust
13	621641	1	2	Valve Plate
14	625094	2	4	Screw - Valve Flapper
15	623137	–	2	O-Ring Valve Plate
16	638281	–	1	Fan - Gray
17	638282	–	1	Fan - Black
18	638581	–	1	Valve - Pressure Relief

Item No.	Part No.	Qty/Unit	Model Number
1	666750	2	2660CE35-190
1	666855	2	2660CE36-190

Wiring Diagram

Use this wiring diagram to connect your compressor to the power source.

2660CE35-190 & 2660CE36-190

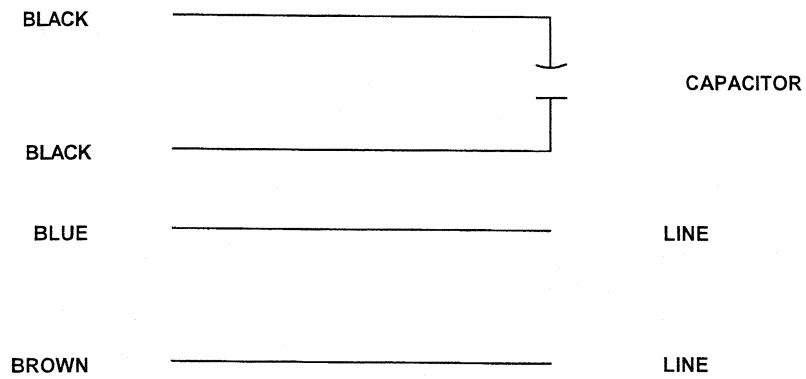

Troubleshooting Guide

If you are having a problem with your compressor, use this table to help determine the cause(s):

Low Flow	Low Pressure	Problem		Loud Unit	Possible Cause	Corrective Action
		Unit Will Not Start	Motor ^① Overheats			
			x		High voltage at compressor	Reduce voltage
x	x	x	x		Low voltage at compressor	Increase voltage
x	x			x	Damaged valves	Replace flapper valves
x	x			x	Debris in valves	Remove debris and check for valve damage
x	x			x	Damaged gaskets	Replace gaskets
x	x			x	Worn Cup	Replace connecting rod assembly or cup
x	x			x	Loose head screws	Tighten head screws
			x		Broken fan	Replace fan
		x	x	x	Bent motor shaft	Replace entire unit
		x	x		Damaged capacitor	Replace capacitor
x					Loose fittings	Tighten fittings
x			x		Insufficient ventilation in enclosure	Increase air circulation to enclosure
		x		x	Worn bearings	Replace eccentric and bearing assembly
				x	Loose rod clamping screw	Apply Loctite® 242 and retighten

① Thermal protector in motor will interrupt current when motor overheats.



2660CE50-190

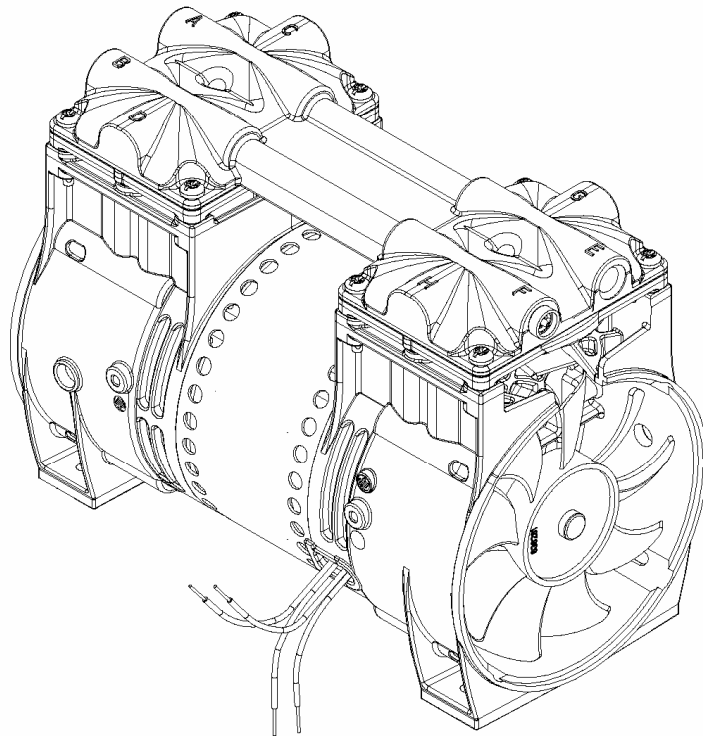

Exploded View and Parts List

Exploded View of the Thomas 2660CE50-190 Compressor

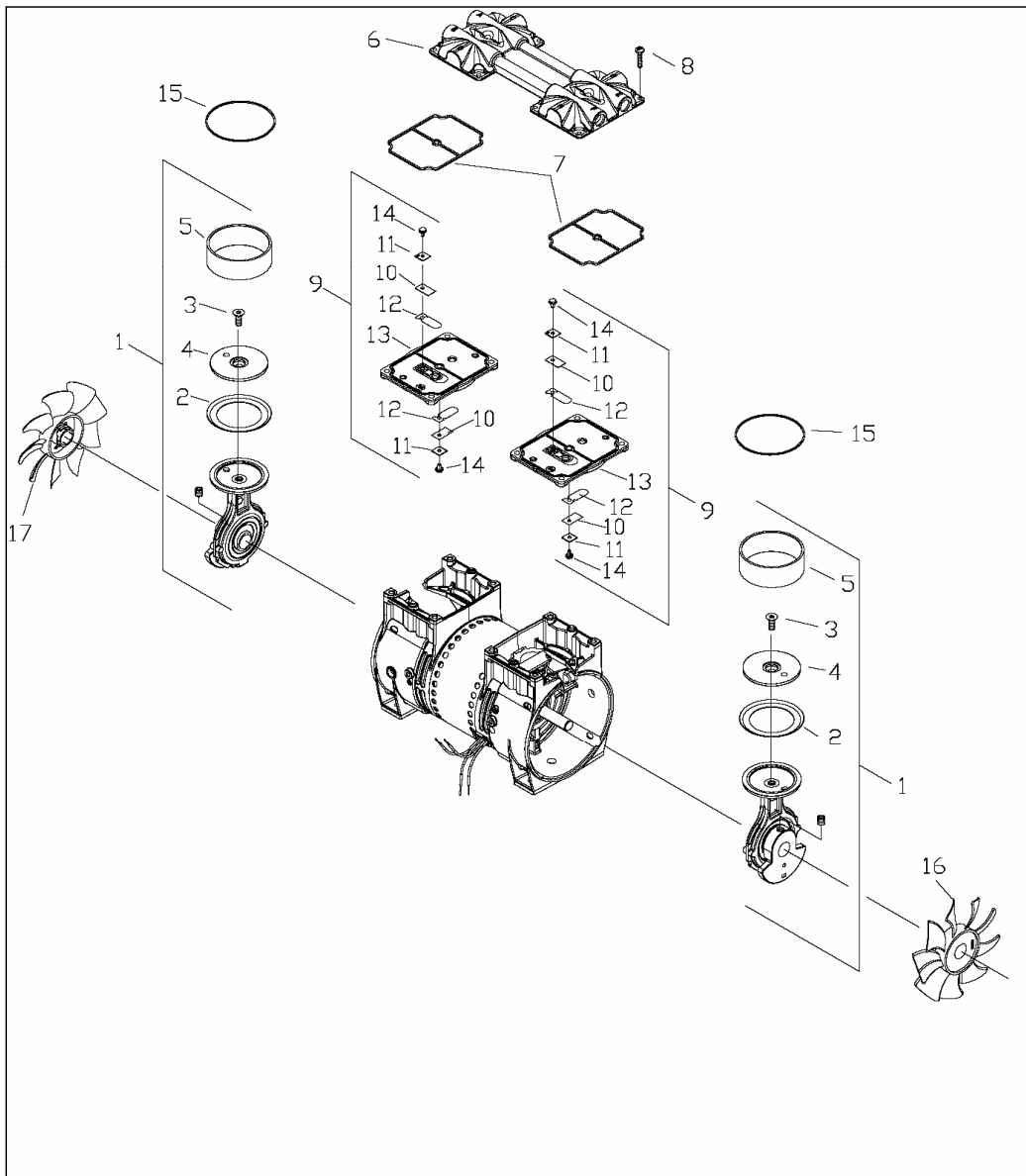

Field Service Parts List for Thomas 2660CE50-190 Compressor

Item No.	Part No.	Qty. Per Assembly	Qty. Per Unit	Description
1	640213	--	2	Connecting Rod, Eccentric & Bearing Ass'y
2	624285	1	2	Piston Cup
3	625776	1	2	Screw - Piston Cup Retainer
4	626577	1	2	Piston Cup Retainer
5	618114	1	2	Cylinder Sleeve
6	662809	--	1	Head
7	623143	--	2	O-Ring - Head Gasket
8	625175	--	8	Screw - Head
9	621780	--	2	Valve Plate Assembly
10	621647	2	4	Valve Retrait
11	617562	2	4	Valve Keeper Strip
12	621485	2	4	Valve Flapper - Intake & Exhaust
13	621641	1	2	Valve Plate
14	625094	2	4	Screw - Valve Flapper
15	623137	--	2	O-Ring Valve Plate
16	638423	--	1	Fan - Gray
17	638424	--	1	Fan - Black
18	638701	--	1	Pressure Relief Valve (Not Shown)
19	623093	--	1	Retaining Clip - PRV (Not Shown)

Wiring Diagram

Use this wiring diagram to connect your compressor to the power source.

2660CE50-190

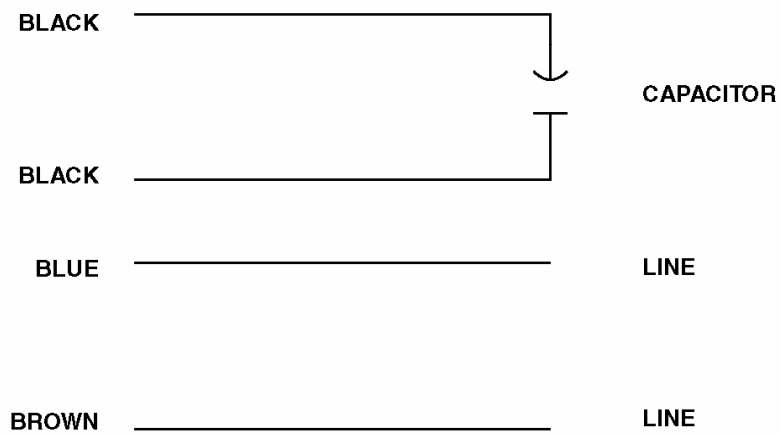

Troubleshooting Guide

If you are having a problem with your compressor, use this table to help determine the cause(s):

Problem					Possible Cause	Corrective Action
Low Flow	Low Pressure	Unit Will Not Start	Motor Overheats	Loud Unit		
			x		High voltage at compressor	Reduce voltage
x	x	x	x		Low voltage at compressor	Increase voltage
x	x			x	Damaged valves	Replace flapper valves
x	x			x	Debris in valves	Remove debris and check for valve damage
x	x			x	Damaged gaskets	Replace gaskets
x	x			x	Worn Cup	Replace connecting rod assembly or cup
x	x			x	Loose head screws	Tighten head screws
			x		Broken fan	Replace fan
		x	x	x	Bent motor shaft	Replace entire unit
		x	x		Damaged capacitor	Replace capacitor
x					Loose fittings	Tighten fittings
x			x		Insufficient ventilation in enclosure	Increase air circulation to enclosure
		x		x	Worn bearings	Replace eccentric and bearing assembly

① Thermal protector in motor will interrupt current when motor overheats.



2660CHI56-190

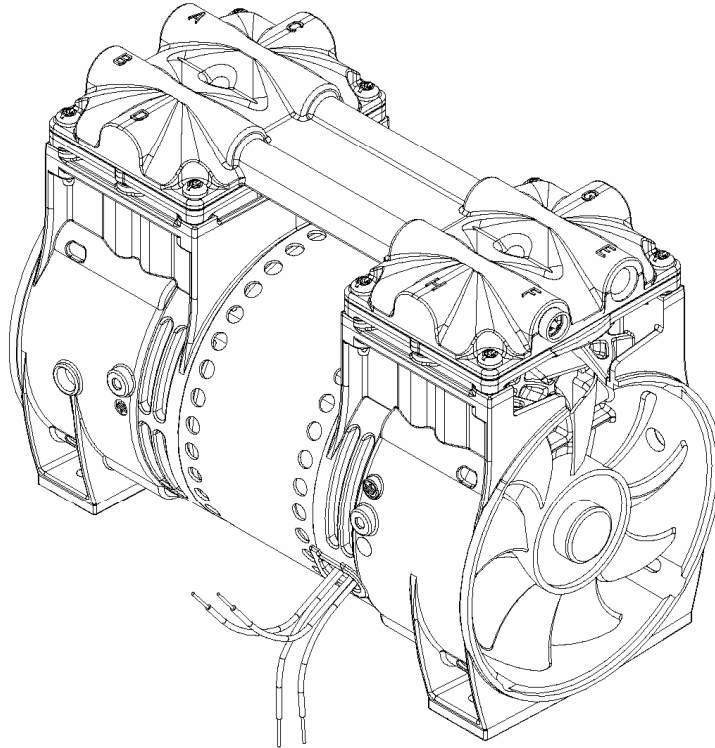

Exploded View and Parts List

Exploded View of the Thomas 2660CHI56-190 Compressor

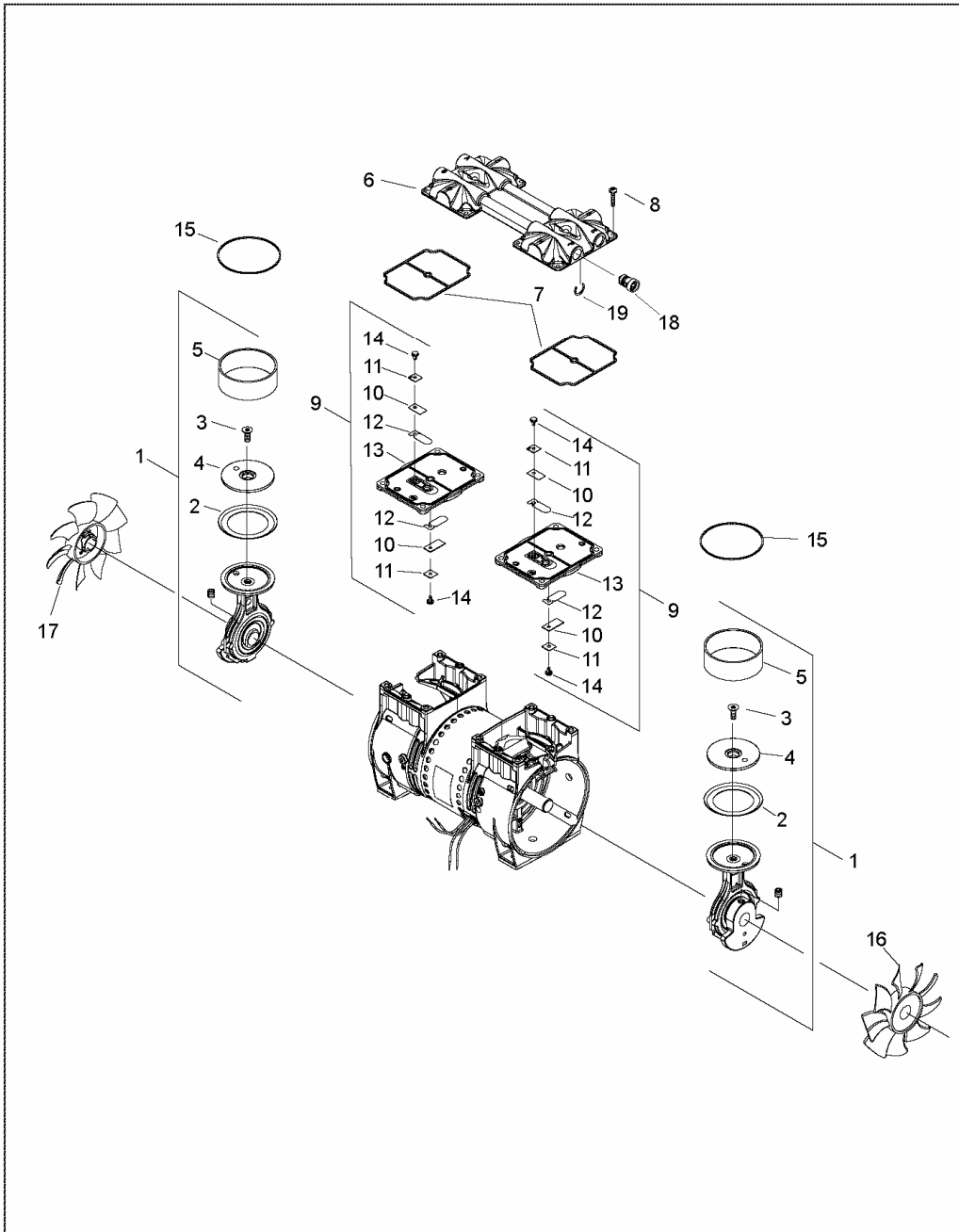

Field Service Parts List for Thomas 2660CHI56-190 Compressor

Item No.	Part No.	Qty. Per Assembly	Qty. Per Unit	Description
1	621780	--	2	Connecting Rod, Eccentric & Bearing Ass'y
2	624285	1	2	Piston Cup
3	625776	1	2	Screw - Piston Cup Retainer
4	626577	1	2	Piston Cup Retainer
5	618114	1	2	Cylinder Sleeve
6	662809	--	1	Head
7	623143	--	2	O-Ring - Head Gasket
8	625175	--	8	Screw - Head
9	621780	--	2	Valve Plate Assembly
10	621647	2	4	Valve Retraint
11	617562	2	4	Valve Keeper Strip
12	621485	2	4	Valve Flapper - Intake & Exhaust
13	621641	1	2	Valve Plate
14	625094	2	4	Screw - Valve Flapper
15	623137	--	2	O-Ring Valve Plate
16	638423	--	1	Fan - Gray
17	638424	--	1	Fan - Black
18	638701	--	1	Pressure Relief Valve
19	623093	--	1	Retaining Clip - PRV

Wiring Diagram

Use this wiring diagram to connect your compressor to the power source.

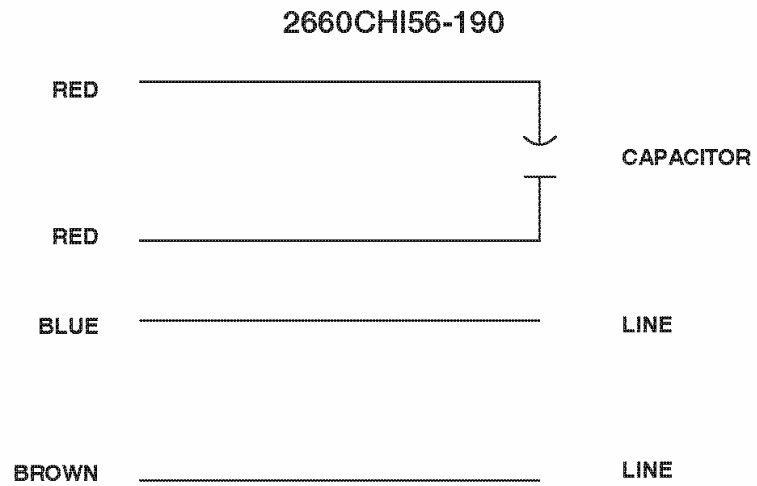

Troubleshooting Guide

If you are having a problem with your compressor, use this table to help determine the cause(s):

Problem					Possible Cause	Corrective Action
Low Flow	Low Pressure	Unit Will Not Start	Motor Overheats	Loud Unit		
			x		High voltage at compressor	Reduce voltage
x	x	x	x		Low voltage at compressor	Increase voltage
x	x			x	Damaged valves	Replace flapper valves
x	x			x	Debris in valves	Remove debris and check for valve damage
x	x			x	Damaged gaskets	Replace gaskets
x	x			x	Worn Cup	Replace connecting rod assembly or cup
x	x			x	Loose head screws	Tighten head screws
			x		Broken fan	Replace fan
		x	x	x	Bent motor shaft	Replace entire unit
		x	x		Damaged capacitor	Replace capacitor
x					Loose fittings	Tighten fittings
x			x		Insufficient ventilation in enclosure	Increase air circulation to enclosure
		x		x	Worn bearings	Replace eccentric and bearing assembly

① Thermal protector in motor will interrupt current when motor overheats.



R01, R04, R06, R07, R08, R11, R14, R15, R16, R17, R18, R46, R64, R72, R74, 11-002, 11-044, 11-111, 20AG

UI-200
6/97
Supersedes 4/97

GENERAL PURPOSE REGULATORS (ENGLISH)

Contact your Norgren supplier for complete instructions and kits.

Installation - Shut off air pressure. Install in air line with air flow in direction of arrow on body. In some cases **IN** may be stamped next to the inlet port.

- upstream of lubricators, and cycling valves. Reverse flow regulators can be installed upstream or downstream of cycling valves.
- as close as possible to the device being served,
- at any angle.

Adjustment - Turn adjustment clockwise to increase and counterclockwise to decrease outlet pressure setting. To reduce pressure, first reduce to a pressure less than that desired, then increase to the desired outlet pressure.

Warning

These products are intended for use in industrial compressed air systems only. Do not use these products where pressures and temperatures can exceed those listed on the product label.

If outlet pressure in excess of the regulator pressure setting could cause downstream equipment to rupture or malfunction, install a pressure relief device downstream of the regulator. The relief pressure and flow capacity of the relief device must satisfy system requirements.

Before using with fluids other than air, for nonindustrial applications, or for life support systems, consult Norgren.

REGOLATORI PER IMPIEGHI GENERICI (ITALIAN)

Contattare il Vostro fornitore Norgren per istruzioni complete e ricambi.

Installazione - Togliere la pressione dell'aria. Posizione sulla linea.

- Con il flusso aria in direzione della freccia riportata sul corpo. In alcuni casi si potrebbe trovare la parola **IN** stampata vicino alla connessione in entrata.
- A monte dei lubrificatori e delle valvole di controllo. I regolatori con flusso contrario possono essere installati sia a valle che a monte delle valvole di controllo.
- Il più vicino possibile all'apparecchio che deve essere alimentato.
- In qualsiasi posizione.

Regolazione - Girare il dispositivo di regolazione in senso orario per aumentare e in senso antiorario per diminuire la pressione di taratura. Per ridurre la pressione, prima di tutto portare la pressione al di sotto del valore desiderato, poi aumentarla fino al valore richiesto.

Avvertenze

Questi prodotti sono adatti esclusivamente all'impiego su sistemi industriali ad aria compressa. Non impiegare in presenza di pressioni e temperature superiori a quelle riportate sulla targhetta.

Se un aumento della pressione in uscita rispetto al valore di taratura dovesse causare rotture o malfunzionamento nell'impianto a valle, installare una valvola limitatrice di pressione a valle del regolatore. La pressione e la capacità di scarico della valvola limitatrice devono soddisfare i requisiti di sicurezza del sistema.

Prima dell'impiego con altri fluidi che non siano aria, per applicazioni non industriali, o in apparecchiature medicali consultare la Norgren.

REGULADORES PARA APLICACIONES GENERALES (PORTUGUESE)

Consulte seu fornecedor Norgren para instruções completas e kits de reparo.

Instalação - Desligue a pressão de ar. Instale na linha de ar.

- Com o fluxo de ar na direção da seta do corpo. Em alguns casos **IN** pode estar gravado próximo ao orifício de entrada.
- Antes dos lubrificadores e válvulas de controle direcional. Os reguladores de fluxo bi-direcionais podem ser instalados antes ou depois das válvulas de controle direcional.
- Tão próximo quanto possível: do dispositivo que está sendo atendido,
- Em qualquer ângulo.

Regulagem - Gire no sentido horário para aumentar e no sentido anti-horário para diminuir a pressão de saída desejada. Para reduzir a pressão, primeiro reduza-a para um valor menor do que desejado e posteriormente aumente até a pressão final.

Advertências

Estes produtos devem ser usados somente em sistemas de ar comprimido industrial. Não os use onde pressões e temperaturas excederem aqueles listados nas etiquetas dos produtos.

Se a pressão de saída for superior à estabelecida podendo causar danos ao equipamento, instale um dispositivo de alívio de pressão após o regulador, que atenda aos requisitos do sistema. Antes de usar outros fluidos para aplicações não industriais ou para sistemas de suporte à saúde, consulte a Norgren.

REGULADORES DE USO GENERAL (SPANISH)

Contacte con su proveedor Norgren para instrucciones completas y kits.

Instalación - Cerrar la presión de aire, instalar en la línea del aire.

- el caudal de aire deberá seguir la dirección de la marca en el cuerpo, en algunos casos la palabra **IN** puede estar impresa al lado de la conexión de entrada
- situarlo antes de los lubricadores y las válvulas de ciclo. Los reguladores de caudal reversible pueden instalarse antes o después de las válvulas de ciclo.
- lo más cerca posible del aparato al que está conectado
- en cualquier ángulo

Regulación - Girar el pomo de regulación en el sentido de las agujas del reloj para aumentar el nivel de presión de salida y en sentido contrario para reducirla. Para disminuir la presión, reducir en primer lugar a un nivel inferior al requerido; después aumentar hasta la presión de salida deseada.

Advertencia

Estos productos se han diseñado para su uso exclusivamente en sistemas industriales de aire comprimido. No usar estos productos en instalaciones en las que las presiones y temperaturas puedan superar las que figuran en la etiqueta del producto.

Si la presión de salida es superior al nivel de presión del regulador, podrían producirse roturas o fallos en los equipos situados después del mismo. En este caso, instalar un aparato con escape de presión después del regulador. La capacidad en cuanto a presión de escape y caudal del mecanismo de descarga deberá satisfacer las necesidades del sistema.

Consultar con Norgren antes de utilizar estos productos con fluidos que no sean el aire, en aplicaciones no industriales o en sistemas de seguridad.

汎用レギュレータ

詳細及びキットに関しては供給元にお問い合わせ下さい。

取付方法:

- 空気圧力を閉じます。
- 本体上の矢印に気流方向を合わせます。入口のポートのところに **IN** と記されている場合があります。
- ルブリケーター、バルブの一次側に取付。逆流レギュレータはバルブの一次側、二次側どちら側でも取付可能。
- 保護する機器に出来るだけ近い位置に取付けます。
- どの角度でも取付けられます。

調整:

圧力設定を上げるには調整ノブを時計方向に、圧力設定を下げるには反時計方向に回します。高い設定値から低い設定値に変更する場合は、目的の圧力よりも低く下げた後、目的の圧力値まで上げるようにして下さい。

注意事項:

当該製品は工業用圧縮空気システムのみ使用できるように作られています。製品ラベル記載以外の温度、圧力では使用出来ません。

出力圧力がレギュレータの設定圧力を超え、レギュレータの二次側にある機器が壊れたり、作動不良が生じる恐れがある場合は、レギュレータの二次側にリリーフバルブを取付けて下さい。減圧装置の減圧および流量はシステムの要求値に合わせなければなりません。

空気以外の媒体や工業用以外の用途、又は生命維持システムに当該製品を使用する場合は、ノルグレン社までお問い合わせ下さい。

通用减压阀

需维修配件和全部使用说明, 请与诺冠供应商接洽。

安装:

先关闭气路, 然後安装减压阀于气路。

- 气体流向与机体上的箭头指向一致, 有时入口端有 **IN** 标记。
- 置减压阀于油雾器和循环阀之前, 反向流减压阀置于循环阀之前或之後。
- 尽量接近所服务的设备。
- 安装角度不限。

调节 - 顺时针转动以增大压力, 逆时针转动以降低压力。降低压力时, 先将压力降至所需压力之下, 然後调高压力至所需压力。

警告 - 本产品仅限于工业压缩空气系统。请勿在超出产品标牌所示的压力和温度范围之外使用。如果输出压力超过设定压力会导致减压阀下游的设备失灵或爆裂, 则应在减压阀下游安装安全阀。安全阀的溢流压力和流量必须满足系统的要求。

欲将本产品用于空气以外的流体, 非工业用途或医疗设备, 请先与诺冠接洽。



R01, R04, R06, R07, R08, R11, R14, R15, R16, R17, R18, R46, R64, R72, R74, 11-002, 11-044, 11-111, 20AG

UI-200
6/97

DRUCKREGLER (GERMAN)

Verschleißteilesätze und ausführliche Hinweise erhalten Sie von Norgren.

Einbau

- Luftzufuhr abstellen.
- Flußrichtungspfeile am Gehäuse beachten. Bei einigen Reglern befindet sich der Schriftzug „IN“ an der Primärseite.
- Vor Olen und Wege-Ventilen installieren. Regler mit Rückschlagventil können sowohl vor als auch hinter den Wege-Ventilen eingebaut werden.
- Einbau in der Nähe der zu versorgenden Geräte vornehmen.
- Einbaulage beliebig

Einstellung

Drehen im Uhrzeigersinn erhöht den Sekundärdruck. Ein neuer niedriger Sekundärdruck wird in zwei Schritten eingestellt. Zunächst unter den gewünschten Druckwert reduzieren. Dann auf den gewünschten Sekundärdruck erhöhen.

Sicherheitshinweise

Die Produkte sind nur für den Einsatz in industriellen Druckluftsystemen geeignet. Die Wartungsgeräte nicht außerhalb der angegebenen Betriebsbedingungen (siehe „Technische Merkmale“), z.B. Druck und Temperatur einsetzen. Falls der maximal einstellbare Sekundärdruck bei nachgeschalteten Geräten zu Fehlfunktionen oder Beschädigungen führen kann, müssen diese durch Druckbegrenzungsventile geschützt werden. Die Druckbegrenzungsventile müssen den Systemanforderungen hinsichtlich Druck und Durchfluß genügen. Anwendungen mit anderen Fluiden als Druckluft oder in medizinischen Geräten sind nur in Absprache mit Norgren erlaubt.

REGULATORER TIL GENERELT FORMAL. (NORWEGIAN)

Kontakt din Norgren leverandør for fullstendig informasjon.

Installasjon

- Steng av trykkluften, installer etter følgende anvisning:
- med strømningsretningen i enhetens pilretning I noen tilfeller vil bokstavene IN være preget ved enhetens inngangsport.
- før smarer og ventiler. Regulatorer med returflow kan også installeres etter ventiler.
- så nær forbruksstedet som mulig.
- Enheten kan monteres i hvilken som helst posisjon.

Justering

Vri justeringsrattet medurs for å øke trykket og moturs for å redusere trykket. For å redusere trykket, juster først til lavere verdi enn ønsket, deretter opp til ønsket trykk.

ADVARSEL.

Disse produkter er kun beregnet til bruk i industrielle trykkluftsystemer. Produktene må ikke benyttes i tilfeller hvor trykk og temperatur kan overstige de verdier som er angitt i produktbeskrivelsen. Dersom systemet er følsomt for trykk over den innstilte verdi bør en avluftningsventil /sikkerhetsventil monteres på regulatorens sekundærside. Ved benyttelse av andre medier enn trykkluft, for ikke industrielle applikasjoner eller i medisinsk sammenheng, ta kontakt med din Norgren leverandør.

REDUCEERVENTIELEN (DUTCH)

Neem contact op met uw Norgren leverancier voor volledige instructies.

Installatie

- Schakel de perslucht-toevoer uit en monteer in luchtleding;
- verticaal met het reservoir naar beneden;
- met luchtstroom in de richting van pijl op het huis; in enkele gevallen is de ingaande poort gemerkt met het woord "IN".
- bovenstrooms van smartoestellen en schakelende ventielen; Terugstroom-uitvoering kan zowel boven- als benedenstrooms van schakelende ventielen geplaatst worden;
- zo dicht mogelijk bij de bediende apparatuur;
- montage in elke stand is mogelijk.

Atstelling: Draai de afstelknop met de wijzers van de klok mee voor een verhoging en tegen de wijzers van de klok in voor een verlaging van de ingestelde druk. Bij een verlaging van de ingestelde druk dient eerst naar een lagere waarde dan naar de gewenste gegaan te worden.

Veiligheid

Deze producten zijn bestemd voor toepassing in industriële persluchtssystemen. Gebruik deze producten niet in situaties waarin druk en/of temperatuur hoger zijn dan aangegeven op het typeplaatje. Indien een hogere dan de ingestelde druk aan secundaire zijde schade of weigering van functioneren kan veroorzaken dient benedenstrooms van het reduceerventiel een ontlastventiel geplaatst te worden. De afblaascapaciteit van het geselecteerde ontlastventiel dient groter te zijn dan de maximaal mogelijke afblaasstroom bij de ingaande poort.

Wij verzoeken u contact met ons op te nemen indien u dit reduceerventiel wilt gaan gebruiken met andere media dan perslucht, in niet-industriële toepassingen of in ademluchtssystemen.

TRYCKREGULATORER GENERELL ANVÄNDNING (SWEDISH)

Kontakta Er Norgren-leverantör för kompletta instruktioner och servicesatser.

Installation

- Stäng av tryckluften och installera enligt följande:
- med luftflöde i pilens riktning, på vissa enheter är IN stämplat vid inloppsporten
- innan smörjapparater och riktningventiler. Regulatorer med reversibelt flöde kan monteras på valfri sida av riktningventiler.
- så nära förbrukningsstället som möjligt
- i valfri position, regulatorer är lägesoberoende.

Justering - Vrid ratten/T-vredet medurs för att öka tryckinställningen eller moturs för att minska tryckinställningen. Vid sänkning av tryck, justera till ett tryck lägre än erforderligt, höj sedan till rätt värde.

Varning

Disse produkter är avsedda enbart för industriella tryckluftsystem. Använd inte enheterna där tryck och temperatur kan överskrida angivna värden.

Om inställt tryck kan stiga över inställt värde i system med känslig utrustning bör en avluftningsventil installeras efter tryckregulatorn. Avluftningsventilens tryckområde och kapacitet måste överensstämma med systemkraven.

Innan användning till andra media än industriell tryckluft, icke industriella applikationer eller livsuppehållande system, kontakta Er Norgren-leverantör.

RÉGULATEURS STANDARD (FRENCH)

Contactez votre agent Norgren le plus proche pour de plus amples renseignements.

Installation

- Couper la pression et installer le régulateur.
- Dans le sens du débit d'air marqué sur le corps, dans certains cas l'orifice d'entrée est marqué "IN".
- En amont du lubrificateur et des distributeurs. Seul un régulateur acceptant un débit en sens inverse peut être installé en aval des distributeurs.
- Au plus près des appareils à alimenter.
- Montage en position quelconque.

Réglage : Tourner le bouton de réglage dans le sens horaire pour augmenter la pression et dans le sens contraire pour la diminuer. Pour réduire la pression : diminuer celle-ci au-dessous de la valeur de consigne et augmenter jusqu'à la pression désirée.

Attention : Ce produit a été conçu pour une utilisation avec de l'air comprimé industriel. Ne pas utiliser ce produit à une pression ou température supérieure à celle indiquée sur l'étiquette, ceci pouvant causer des ruptures ou un mauvais fonctionnement. La pression et le débit doivent satisfaire aux besoins de l'installation.

Si un excès de pression en provenance du régulateur peut endommager ou gêner le fonctionnement des appareils situés en aval de celui-ci, installer une soupape de décharge entre le régulateur et ces appareils. Le seuil de déclenchement ainsi que les caractéristiques de débit de la soupape doivent être choisis pour satisfaire aux exigences des appareils à protéger.

REGULATOR (DANISH)

Kontakt deres Norgren leverandør for yderligere teknisk information og reservedele.

Montering

- Luften afspærrer og regulatoren monteres på følgende måde:
- Med luftgennemstrømning i samme retning som pilen på huset. I visse tilfælde kan der være stemplet IN ved siden af indgangsporten.
- Før smareapparat og andre pneumatikkomponenter. Regulator med mulighed for returgenemstrømning kan monteres på både før og efter ventiler.
- Så tæt som muligt på den enhed hvor den regulerede luft anvendes
- I en hvilken som helst vinkel.

Justering - Drej justeringsgreb med uret for at øge og mod uret for at reducere sekundærtrykket. Ved justering til lavere sekundærtryk, justér da ned til et lavere tryk end ønsket og derefter op til det ønskede.

Advarsel

Disse enheder er kun til brug i industrielle trykkluftsystemer. Anvend ikke enhederne hvor tryk og temperatur overstiger de angivne værdier.

Hvis sekundærtrykket kan overstige regulatorens fastsatte indstilling og dermed give funktionstøj eller ødelæggelse udstyr, skal en overtryksventil monteres efter regulatoren. Gennemstrømnings- og trykkapacitet for overtryksventil skal svare til systemkravene. Kontakt venligst Norgren for anvendelse af regulator til andre gasser end luft, i ikke industrielle sammenhænge eller til friskluft systemer.

Solenoid Valve Assembly Diagram

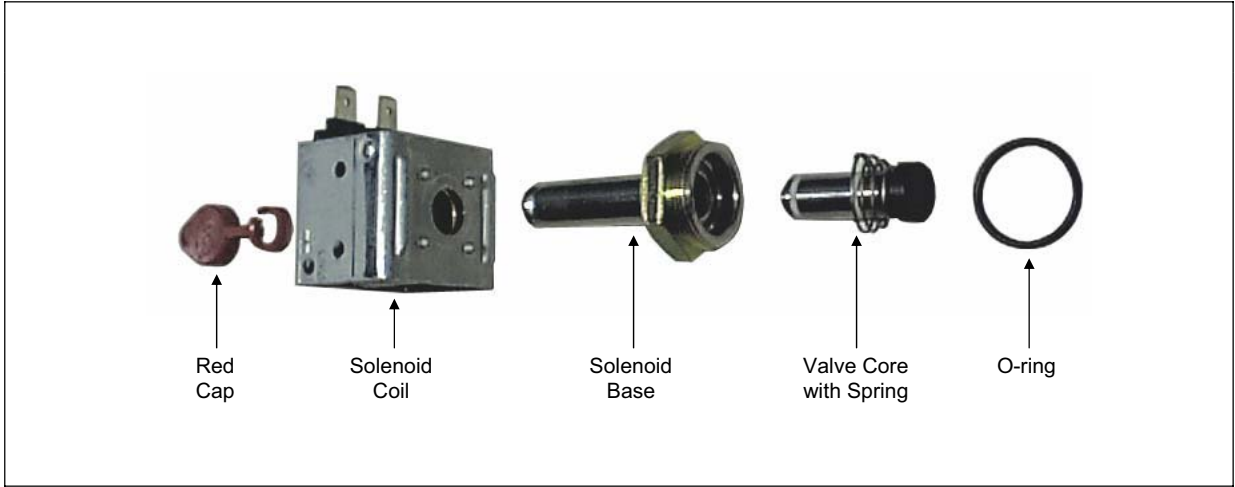

Installation & Maintenance Instructions

OPEN-FRAME SOLENOIDS

SERIES
U8016
US8016

Form No.V6917R1

NOTICE: See separate valve installation and maintenance instructions for information on: Operation, Positioning, Mounting, Piping, Strainer or Filter Requirements, Flow Controls, Cleaning, Preventive Maintenance, Causes of Improper Operation, Disassembly and Reassembly of Basic Valve.

DESCRIPTION

Series U8016 are open-frame, pull type solenoid operators. When installed just as a solenoid and not as part of an ASCO valve, the core has a 0.250-28 UNF-2B tapped hole with 0.38 minimum full thread.

Series US8016 open-frame solenoid operators are the same as Series U8016 except they are provided with spade terminal coils.

OPERATION

When the solenoid is energized, the core is drawn into the solenoid base sub-assembly.

IMPORTANT: When the solenoid is de-energized, the initial return force for the core, whether developed by spring, pressure or weight, must exert a minimum force to overcome residual magnetism created by the solenoid. Minimum return force for AC construction is 11 ounces; 5 ounces for DC construction.

INSTALLATION

Check nameplate for correct catalog number, voltage, frequency, wattage and service.

▲ CAUTION: To protect the solenoid valve or operator, install a strainer or filter, suitable for the service involved in the inlet side as close to the valve or operator as possible. Clean periodically depending on service conditions. See ASCO Series 8600, 8601 and 8602 for strainers.

▲ WARNING: To prevent the possibility of electrical shock from the accessibility of live parts, install the open-frame solenoid in an enclosure.

Positioning

This solenoid is designed to perform properly when mounted in any position. However, for optimum life and performance, the solenoid should be mounted vertically and upright to reduce the possibility of foreign matter accumulating in the solenoid base sub-assembly area.

If open-frame solenoid is supplied on an ASCO valve, check basic valve instructions for positioning.

Mounting

Refer to Figure 1 (below) for mounting.

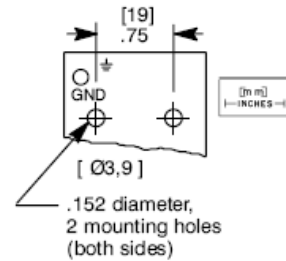

▲ CAUTION: Be sure mounting screws do not penetrate yoke far enough to damage coil.

Figure 1. Yoke mounting dimension (partial view).

Wiring

Wiring must comply with local codes and the National Electrical Code. Coils are provided with lead wires or 1/4" spade terminals. The solenoid yoke is provided with a hole for a grounding screw, see Figure 2. Grounding screw not supplied with solenoid. To facilitate wiring, the solenoid may be rotated 360° by removing the retaining cap, clip or hi-shock clip.

▲ CAUTION: When metal retaining clip disengages, it will spring upward.

Rotate solenoid enclosure to desired position. Then replace retaining cap, clip or hi-shock clip before operating. Be sure hi-shock retaining clip seats in the circular groove around side wall of solenoid base sub-assembly. Tighten retaining clip securely so that the retaining clip ends meet.

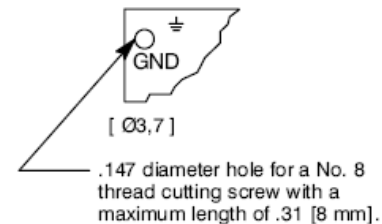

Figure 2. Hole for grounding screw (partial view).

© ASCO®

MM All Rights Reserved.

Printed in U.S.A.

Page 1 of 4

50 Hanover Road, Florham Park, New Jersey 07932 www.ascovalve.com

Note: Alternating current (AC) and direct current (DC) solenoids are built differently. To convert from one to the other, it is necessary to change the complete solenoid including the core and solenoid base sub-assembly, not just the coil. Consult ASCO.

Solenoid Enclosure Assembly

Catalog Numbers U80161, U80162, US80161 and US80162 open-frame solenoids may be assembled as a complete unit. Tightening is accomplished by means of a hex flange at the base of the solenoid.

▲ CAUTION: Care must be taken not to mar the upper core surface, when installing core or positioning solenoid.

Solenoid Temperature

Standard solenoids are supplied with coils designed for continuous duty service. When the solenoid is energized for a long period, the solenoid yoke becomes hot. This is a safe operating temperature. Any excessive heating will be indicated by the smoke and odor of burning coil insulation.

MAINTENANCE

▲ WARNING: To prevent the possibility of death, serious injury or property damage, turn off electrical power, depressurize solenoid operator or valve, and vent fluid to a safe area before servicing.

Cleaning

All solenoid operators and valves should be cleaned periodically. The time between cleanings will vary depending on the medium and service conditions. In general, if the voltage to the coil is correct, sluggish valve operation, excessive noise or leakage will indicate that cleaning is required. In the extreme case, faulty operation will occur and the solenoid operator or valve may fail to shift. Clean strainer or filter when cleaning the operator or valve.

Preventive Maintenance

- Keep the medium flowing through the solenoid operator or valve as free from dirt and foreign material as possible.
- While in service, the solenoid operator or valve should be operated at least once a month to insure proper opening and closing.
- Depending on the medium and service conditions, periodic inspection of internal valve parts for damage or excessive wear is recommended. Thoroughly clean all parts. Replace any worn or damaged parts.

Causes of Improper Operation

- **Faulty Control Circuit:** Check the electrical system by energizing the solenoid. A metallic *click* signifies that the solenoid is operating. Absence of the *click* indicates loss of power supply. Check for loose or blown fuses, open-circuited or grounded solenoid, broken lead wires or splice connections.
- **Burned-Out Coil:** Check for open-circuited coil. Replace if necessary. Check supply voltage; it must be the same as specified on nameplate and marked on the

coil. Check ambient temperature and check the core is not jammed.

- **Low Voltage:** Check voltage across the coil leads. Voltage must be at least 85% of rated voltage.

Coil Replacement/Solenoid Disassembly

1. Disassemble solenoid in an orderly fashion using exploded views for identification and placement of parts.
2. Disconnect coil lead wires from power supply and grounding wire from yoke.
3. Remove retaining cap, clip or hi-shock clip and spacer (if present) from top of solenoid.

▲ CAUTION: When metal retaining clip disengages, it will spring upward.

4. Slip yoke containing coil, sleeves and insulating washers off the solenoid base sub-assembly. Insulating washers are omitted when a molded coil is used.
5. Remove coil, sleeves (2) and insulating washers (if present) from yoke.

Note: for panel mount (Figure 6) or hi-shock (Figure 5) construction remove additional parts as required.

6. For additional disassembly, unscrew solenoid base sub-assembly or bonnet. The bonnet requires a special wrench adapter which is supplied in ASCO Rebuild Kits. For wrench adapter only, order Wrench Kit No. K218948.
7. Refer to basic valve instructions for further disassembly.

Coil Replacement/Solenoid Reassembly

1. Install solenoid base sub-assembly or plugnut/core tube sub-assembly with bonnet gasket and bonnet. Torque solenoid base sub-assembly to 175 ± 25 in-lbs [$19,8 \pm 2,8$ Nm]. Torque valve bonnet to 90 ± 10 in-lbs [$10,2 \pm 1,1$ Nm].
2. Reassemble open-frame solenoid following exploded views.
3. For solenoid using a hi-shock retaining clip be sure retaining clip seats in circular groove around side wall of solenoid base sub-assembly. Then tighten retaining clip securely so that the retaining clip ends meet.
4. Make electrical connections to solenoid, see *Wiring* section.

▲ CAUTION: Solenoid must be fully reassembled because the yoke and internal parts complete the magnetic circuit. Be sure to replace insulating washer at each end of non-molded coil.

ORDERING INFORMATION FOR SOLENOID OPERATORS OR COILS

When Ordering Solenoid Operators or Coils, specify Catalog Number, Serial Number, Voltage and Frequency. For Coils, specify number stamped on coil (if visible).

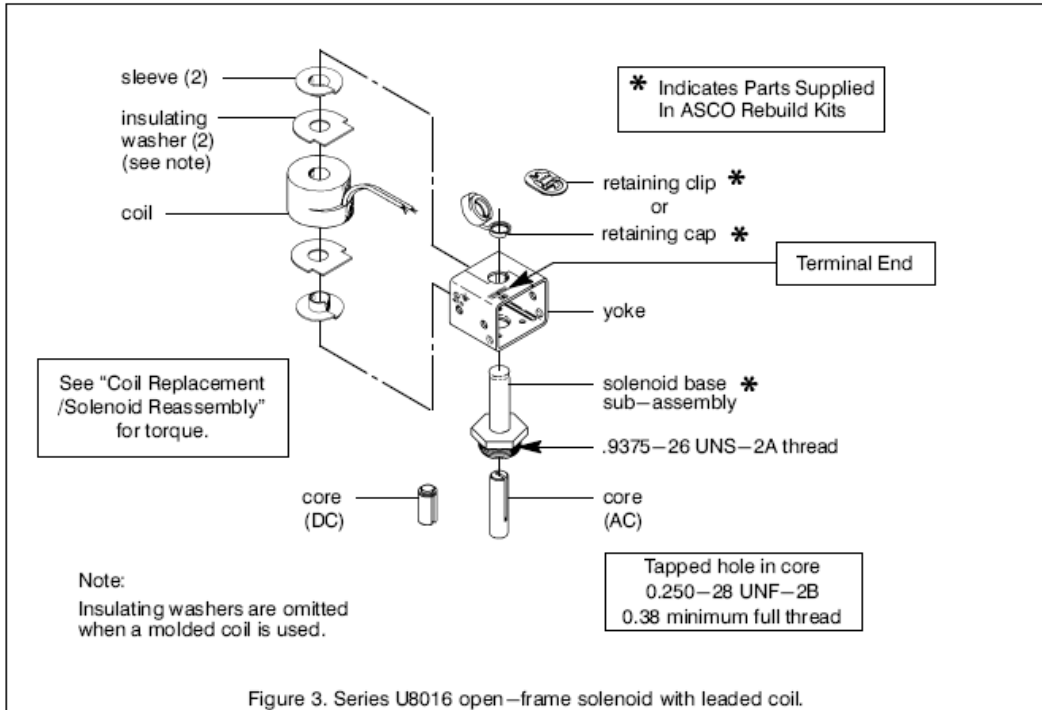

Figure 3. Series U8016 open-frame solenoid with leaded coil.

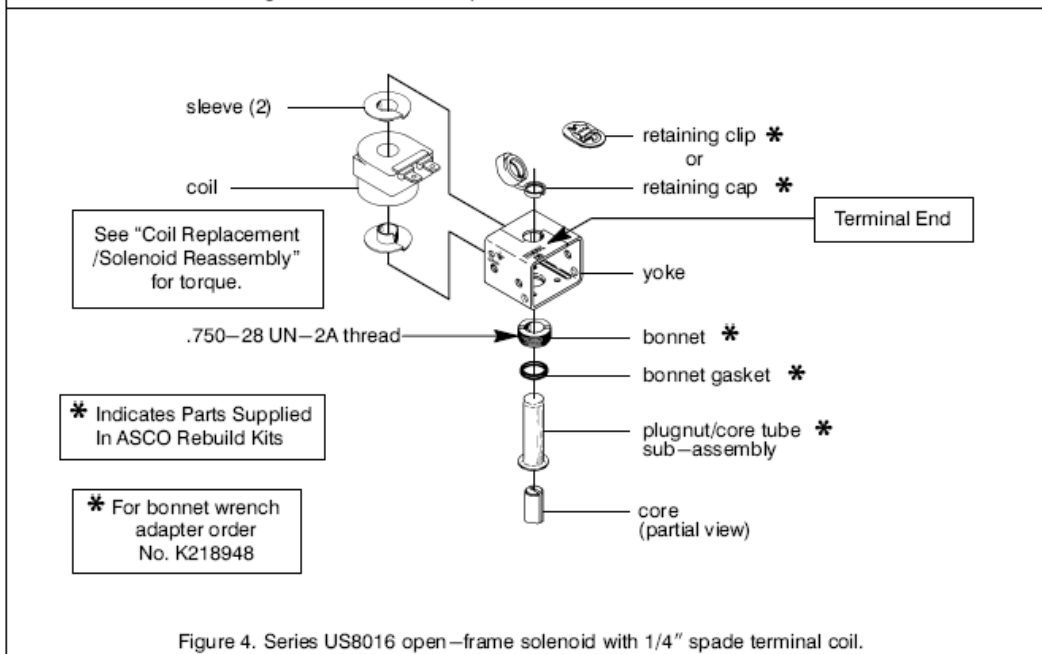

Figure 4. Series US8016 open-frame solenoid with 1/4" spade terminal coil.

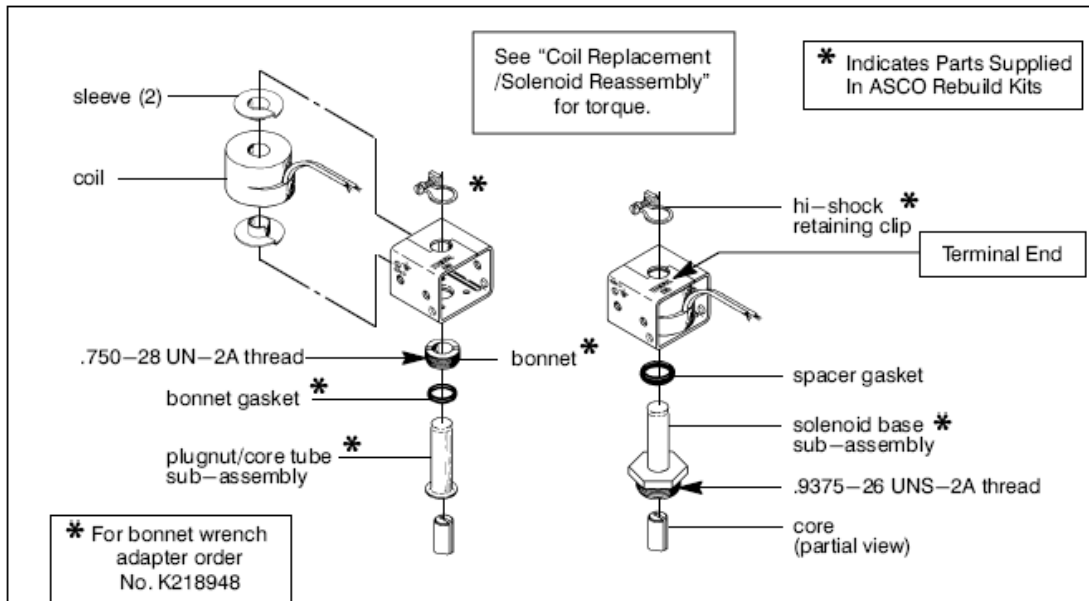

Figure 5. Series U8016 hi-shock clip construction - open-frame solenoid with leaded coil.

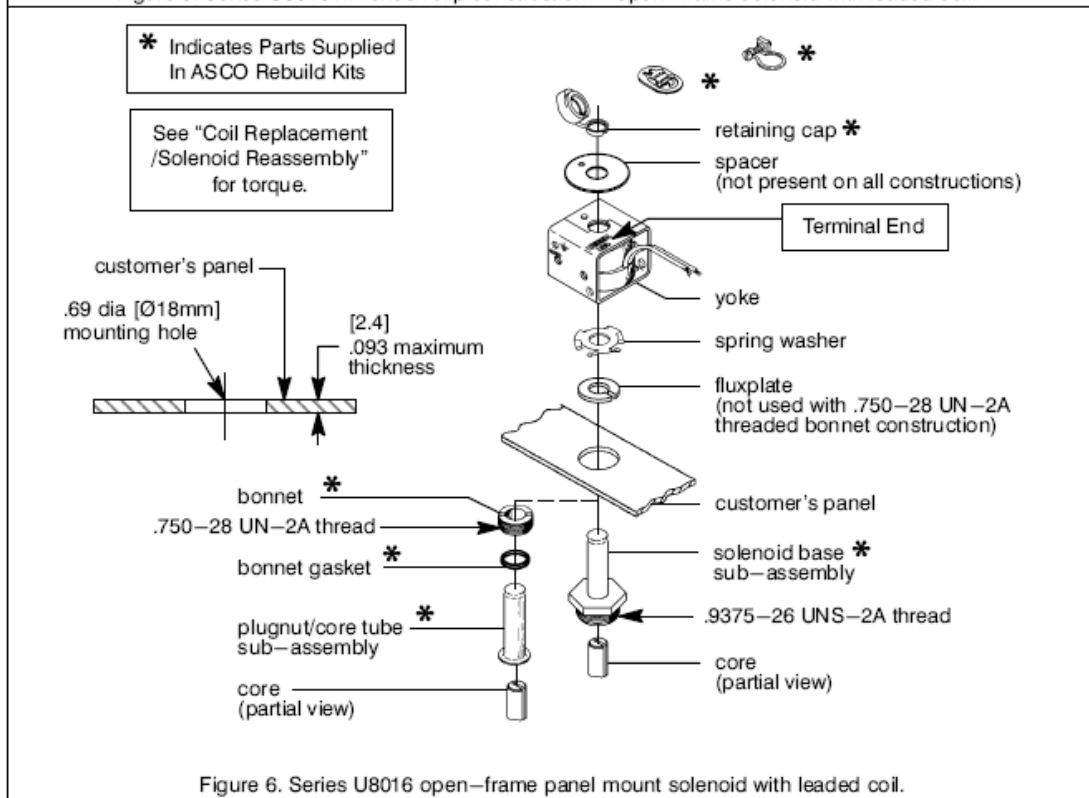

Figure 6. Series U8016 open-frame panel mount solenoid with leaded coil.

General Installation & Maintenance Instructions

Drawing No.
214639-107
October - 2003

DESCRIPTION

This sheet is specifically designed to provide general installation and maintenance instructions for specially designed valves. Not all paragraphs on this sheet are applicable to each design. You must review this sheet and select the paragraphs which apply to the valves you have. This sheet is designed to cover a wide range of valve designs, for example: solenoid operated valves, air operated valves, manual operated valves, special designs for special applications and conditions. Refer to the offset assembly drawing which is packaged with your valve for information on size, type, material, and operation.

OPERATION

Refer to assembly drawing for flow diagrams and general instructions on operation.

INSTALLATION

Check nameplate for correct catalog number, pressure, voltage, service and valve for any other special instruction tags or labels. Never apply incompatible fluids or exceed pressure rating of the valve. Installation and valve maintenance to be performed by qualified personnel.

FOR VALVES WITH LEVER TYPE OPERATING MOVEMENTS

▲ WARNING: Do not obstruct movement of lever. Lever must be free to move or valve will not shift position.

Future Service Considerations

Provision should be made for performing seat leakage, external leakage, and operational tests on the valve with a nonhazardous, noncombustible fluid after disassembly and reassembly.

Temperature Limitations

Refer to assembly drawing for ambient and fluid temperature limitations.

Positioning

Refer to assembly drawing for positioning.

Piping

Connect piping to valve according to markings on valve body (consult flow diagrams on assembly drawings). Apply pipe compound sparingly to male pipe threads only. If applied to valve threads the compound may enter the valve and cause operational difficulty. Avoid pipe strain by properly supporting and aligning piping. When tightening the pipe, do not use valve or solenoid as a lever. Locate wrenches applied to valve body or piping as close as possible to connection point.

▲ CAUTION: To avoid damage to the valve body, DO NOT OVERTIGHTEN PIPE CONNECTIONS. If TEFLON† tape, paste, spray or similar lubricant is used, use extra care when tightening due to reduced friction. This applies mainly to valves with aluminum or zinc bodies.

▲ CAUTION: For the protection of the solenoid valve (all valves in general) install a strainer or filter suitable for the service involved in the inlet side as close to the valve as possible. Periodic cleaning is required depending on service conditions. See Series 8600, 8601 and 8602 for strainers.

Minimum Operating Pressure Differential

For all valves requiring a minimum operating pressure differential, the pressure and exhaust lines must be full size without restriction. Minimum operating pressure differential as stamped on the nameplate must be maintained for dependable operation. For 3 and 4-way valves minimum operating pressure differential must be maintained between pressure and exhaust at the moment of changeover. Hydraulic pumps or air reservoirs must have adequate capacity to maintain the minimum pressure during changeover. To check pressure during changeover, install a pressure gage in the pressure connection as close as possible to the valve.

MAINTENANCE

▲ WARNING: To prevent the possibility of death, serious injury or property damage, turn off electrical power and depressurize valve. If the valve handles combustible fluid, extinguish all open flames and avoid any type of sparking or ignition. Vent fluid to a safe area before servicing the valve.

NOTE: For most valves it is not necessary to remove valve from pipeline for repairs. For air operated valves the auxiliary pressure line must be disconnected.

Cleaning

All solenoid valves should be cleaned periodically. The time between cleanings will vary depending on the medium and service conditions. In general, if the voltage to the coil is correct, sluggish valve operation, excessive noise or leakage will indicate that cleaning is required. In the extreme case, faulty valve operation will occur and the valve may fail to shift. Clean strainer or filter when cleaning the valve.

Preventive Maintenance

- Keep medium flowing through valve as free from dirt and foreign material as possible.
- Periodic exercise of the valve should be considered if ambient or fluid conditions are such that corrosion, elastomer degradation, fluid contamination build up, or other conditions that could impede solenoid valve shifting are possible. The actual frequency of exercise necessary will depend on specific operating conditions. A successful operating history is the best indication of a proper interval between exercise cycles.
- Depending on the medium and service conditions, periodic inspection of internal valve parts for damage or excessive wear is recommended. Thoroughly clean all parts. If parts are worn or damaged, install a complete rebuild kit.
- For special designs where an operating movement is utilized, periodic inspection of the movement should be carried out. Operating movement should be kept clean and free from paint, foreign matter, corrosion, freezing and icing conditions.

Causes Of Improper Operation

- **Faulty Control Circuits:** Check the electrical system by energizing the solenoid. A metallic *click* signifies that the solenoid is operating. Absence of the *click* indicates loss of power supply. Check for loose or blown fuses, open circuited or grounded coil, broken lead wires, or splice connections.
- **Burned-Out Coil:** Check for open-circuited coil. Replace coil as necessary. Check supply voltage; it must be the same as specified on nameplate and as marked on the coil.
- **Low Voltage:** Check coil voltage across coil leads. Voltage must be at least 85% of nameplate rating.
- **Incorrect Pressure:** Check valve pressure. Pressure to valve must be within range specified on nameplate.
- **Air Operator:** Check line pressure to air operator.
- **Excessive Leakage:** Disassemble valve and clean all parts. Replace worn or damaged parts with a complete ASCO Rebuild Kit for best results.

ORDERING INFORMATION FOR ASCO REBUILD KITS AND COILS

Parts marked with an asterisk (*) on the assembly drawing are supplied in Rebuild Kits. When Ordering Rebuild Kits for ASCO valves, order the Rebuild Kit number stamped on the valve nameplate. When Ordering Coils for ASCO valves, order the number stamped on your coil. If the number of the kit or the coil is not visible, order by indicating the number of kits required, and the Catalog Number and Serial Number of the valve(s) for which they are intended.

† Dupont Co. Registered Trademark

ASCO®

50 Hanover Road, Florham Park, New Jersey 07932 www.ascovalve.com

V5779R4

All Rights Reserved.

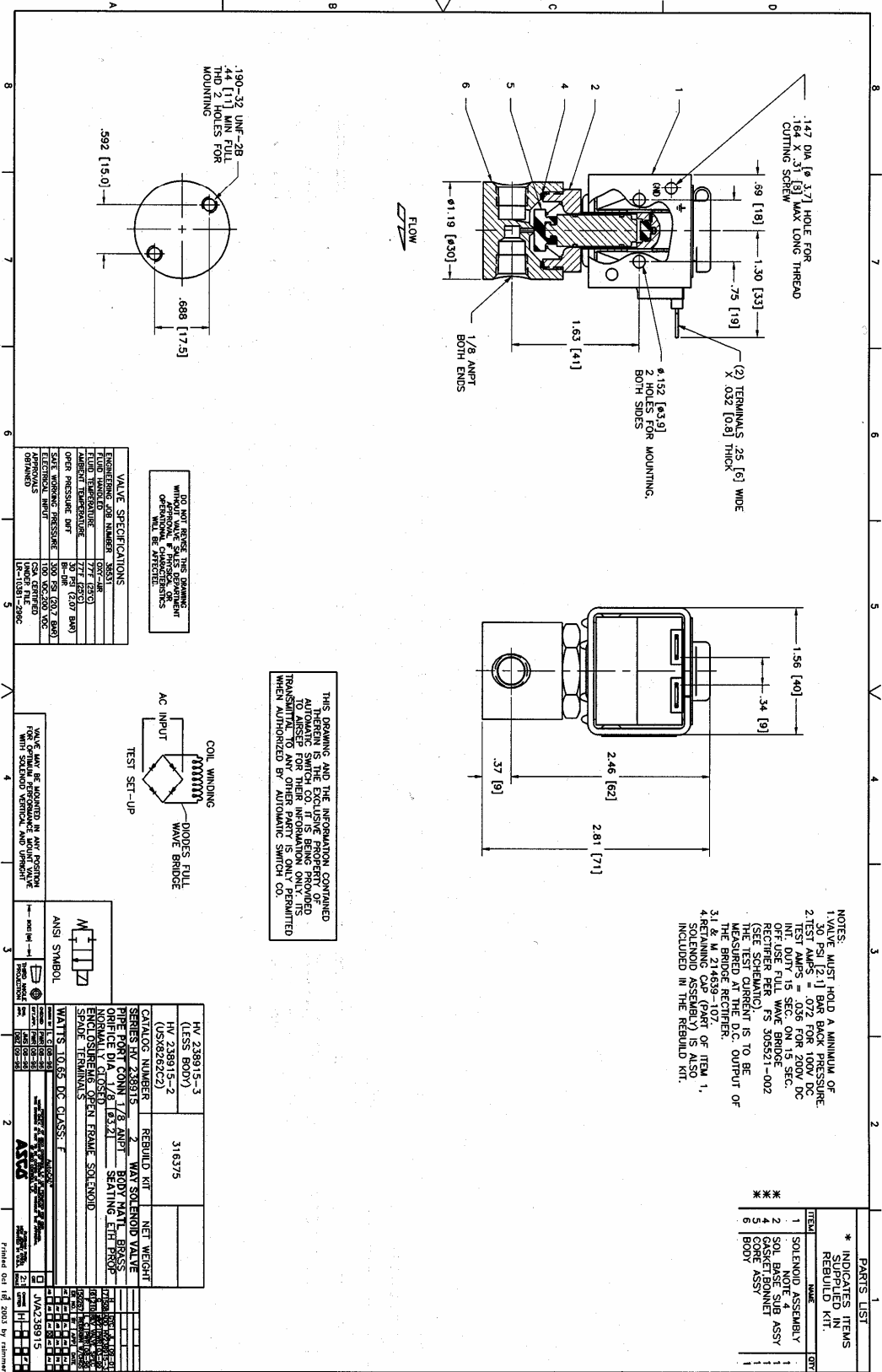

PARTS LIST

* INDICATES ITEMS SUPPLIED IN REBUILD KIT.

ITEM	NAME	QTY
1	SOLENOID ASSEMBLY	1
2	SOL. BASE SUB ASSY	1
3	GASKET/BONNET	1
4	BONNET ASSY	1
5	SOLENOID ASSEMBLY	1

NOTES:
 1. VALVE MUST HOLD A MINIMUM OF 30 PSI [2.1] BAR BACK PRESSURE.
 2. TEST AMPS = .072 FOR 100V DC INFLUENT, .072 FOR 115V DC OFF USE FULL WAVE BRIDGE RECTIFIER PFR FS 305521-002 (SEE SCHEDULE) THAT IS TO BE MEASURED AT THE D.C. OUTPUT OF THE BRIDGE RECTIFIER.
 3. 1 & M 214639-107 OF ITEM 4 (SOL. BASE ASSY) IS ALSO INCLUDED IN THE REBUILD KIT.

THIS DRAWING AND THE INFORMATION CONTAINED HEREIN IS THE EXCLUSIVE PROPERTY OF AIRSEP CORPORATION. NO PARTS MAY BE REPRODUCED OR TRANSMITTED IN ANY FORM OR BY ANY MEANS, ELECTRONIC OR MECHANICAL, WITHOUT PERMISSION IN WRITING WHEN AUTHORIZED BY AIRSEP CORPORATION.

DO NOT REMOVE THIS DRAWING WITHOUT THE PERMISSION OF AIRSEP CORPORATION. OPERATIONAL CHARACTERISTICS MAY VARY.

VALVE SPECIFICATIONS

ENGINEERING JOB NUMBER	30551
FLUID TEMPERATURE	77°F (25°C)
ASSEMBLY TEMPERATURE	77°F (25°C)
OPER. PRESSURE DIFF.	BR - DR (CAT. MAX)
SOLENOID WORKING PRESSURE	100 PSI (6.9 BAR)
SOLENOID HOLDING PRESSURE	100 PSI (6.9 BAR)
APPROVALS	CSA CERTIFIED UNDER THE CANADIAN STANDARD C22.2 NO. 195

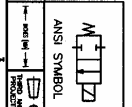
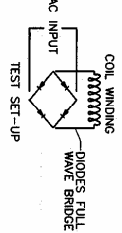

HW 238915-3 (LESS BODY)	318375	NET WEIGHT
HW 238915-2 (USX8262C2)		
CATALOG NUMBER	REBUILD KIT	
SERIES HW 238915	2	WAY SOLENOID VALVE
PIPE PORT CONN 1/8 ANPT		BODY MATE BRASS
PISTON VALVE		SEATING LEH FEND
ENCLOSURE OPEN FROUD - SOLENOID		SPADE TERMINALS

Printed on 12/20/01 by retransmission

Installation & Maintenance Instructions

2-WAY DIRECT-ACTING SOLENOID VALVES
 NORMALLY OPEN OR NORMALLY CLOSED OPERATION
 BRASS OR STAINLESS STEEL CONSTRUCTION – 1/8", 1/4", OR 3/8" NPT

SERIES

**8262
8263**

Form No.V5256R9

IMPORTANT: See separate solenoid installation and maintenance instructions for information on: Wiring, Solenoid Temperature, Causes of Improper Operation, and Coil or Solenoid Replacement.

DESCRIPTION

Series 8262 and 8263 valves are 2-way direct-acting general service solenoid valves. Valves bodies are of rugged brass or stainless steel. Series 8262 or 8263 valves may be provided with a general purpose or explosionproof solenoid enclosure. Series 8262 and 8263 valves with suffix "P" in the catalog number are designed for dry inert gas and non-lubricated air service.

OPERATION

Normally Open: Valve is open when solenoid is de-energized; closed when is energized.

Normally Closed: Valve is closed when solenoid is de-energized; open when energized.

IMPORTANT: No minimum operating pressure required.

Manual Operation

Manual operator allows manual operation when desired or during an electrical power outage. Depending upon basic valve construction, three types of manual operators are available:

Push Type Manual Operator

To engage push type manual operator, push stem at base of valve body upward as far as possible. Valve will now be in the same position as when the solenoid is energized. To disengage manual operator, release stem. Manual operator will return to original position.

Screw Type Manual Operator

To engage screw type manual operator, rotate stem at base of the valve body clockwise until it hits a stop. Valve will now be in the same position as when the solenoid is energized. To disengage, rotate stem counterclockwise until it hits a stop.

▲ CAUTION: For valve to operate electrically, manual operator stem must be fully rotated counterclockwise.

Stem/Lever Type Manual Operator

To engage manual operator, turn stem/lever clockwise until it hits a stop. Valve will now be in the same position as when the solenoid is energized. To disengage manual operator, turn stem/lever counterclockwise until it hits a stop.

▲ CAUTION: For valve to operate electrically, manual operator stem/lever must be fully rotated counterclockwise.

Flow Metering Devices

Valves with suffix "M" in catalog number are provided with a metering device for flow control. Turn stem to right to reduce flow; left to increase flow.

INSTALLATION

Check nameplate for correct catalog number, pressure, voltage, frequency, and service. Never apply incompatible fluids or exceed pressure rating of the valve. Installation and valve maintenance to be performed by qualified personnel.

Note: Inlet port will either be marked "I" or "IN". Outlet port will be marked "2" or "OUT".

Future Service Considerations.

Provision should be made for performing seat leakage, external leakage, and operational tests on the valve with a nonhazardous, noncombustible fluid after disassembly and reassembly.

Temperature Limitations

For maximum valve ambient and fluid temperatures, refer to charts below. Check catalog number, coil prefix, suffix, and watt rating on nameplate to determine the maximum temperatures.

Wattage	Catalog Number Coil Prefix	Coil Class	Max. Ambient Temp. °F	Max. Fluid Temp. °F
6, 10.5, 12.4	none, DA or S	A	77	180
6,10.5 12.4	DF, FT or SF	F	125	180
6,10.5, 12.4	HT	H	140	180
9,10.7	none, DP or SP	F	77	180
9.7	none, FT or HT	A, F or H	77	120
11.2	none, FT or HT	A, F or H	77	150
16.7	none, DP or SP	F	77	200
17.1	none, KP SP or SD	F	125	180
17.1	HB, KB SS or SV	H	140	180

Catalog Nos.8262B200 and 8262 C200 AC construction only and Catalog Nos.8262B214 and 8262 D200 AC and DC construction are limited to 140°F fluid temperature.

Valves with Suffix V or W that are designed for AC service and normally closed operation are for use with No. 2 and 4 fuel oil service. These valves have the same maximum temperatures per the above table except Suffix W valves are limited to a maximum fluid temperature of 140°F.

Listed below are valves with Suffix V in the catalog number that are acceptable for higher temperatures.

Catalog Number Coil Prefix	Max. Ambient Temp. °F	Max. Fluid Temp. °F
FT8262, HB8262 FT8263, HB8263 8262G, 8263G	125	250*
HT or HB 8262G HT or HB 8263G	140	250

*The only exception is the 8262G and 8263G series (Class F coil) at 50 Hertz rated 11.1 and 17.1 watts are limited to 210°F fluid temperature.

Positioning

This valve is designed to perform properly when mounted in any position. However, for optimum life and performance, the solenoid should be mounted vertically and upright to reduce the possibility of foreign matter accumulating in the solenoid base sub-assembly area.



MM All Rights Reserved.

Printed in U.S.A.

Page 1 of 4

50 Hanover Road, Florham Park, New Jersey 07932 www.ascovalve.com

Valves with suffix "P" in the catalog number must be mounted with the solenoid vertical and upright.

Mounting

Refer to Figure 2 for mounting dimensions.

Piping

Connect piping or tubing to valve according to markings on valve body. Inlet port will either be marked "I" or "IN". Outlet port will be marked "O" or "OUT". Wipe the pipe threads clean of cutting oils. Apply pipe compound sparingly to male pipe threads only. If applied to valve threads, the compound may enter the valve and cause operational difficulty. Avoid pipe strain by properly supporting and aligning piping. When tightening the pipe, do not use valve or solenoid as a lever. Locate wrenches applied to valve body or piping as close as possible to connection point.

IMPORTANT: To protect the solenoid valve, install a strainer or filter suitable for the service involved, in the inlet side as close to the valve as possible. Clean periodically depending on service conditions. See ASCO Series 8600, 8601 and 8602 for strainers.

MAINTENANCE

▲ WARNING: To prevent the possibility of death, serious injury or property damage, turn off electrical power, depressurize valve, and vent fluid to a safe area before servicing the valve.

NOTE: It is not necessary to remove the valve from the pipeline for repairs.

Cleaning

All solenoid valves should be cleaned periodically. The time between cleanings will vary depending on the medium and service conditions. In general, if the voltage to the coil is correct, sluggish valve operation, excessive noise or leakage will indicate that cleaning is required. In the extreme case, faulty valve operation will occur and the valve may fail to open or close. Clean strainer or filter when cleaning the valve.

Preventive Maintenance

- Keep the medium flowing through the valve as free from dirt and foreign material as possible.
- While in service, the valve should be operated at least once a month to insure proper opening and closing.
- Depending on the medium and service conditions, periodic inspection of internal valve parts for damage or excessive wear is recommended. Thoroughly clean all parts. If parts are worn or damaged, install a complete ASCO Rebuild Kit.

Causes of Improper Operation

- **Incorrect Pressure:** Check valve pressure. Pressure to valve must be within range specified on nameplate.
- **Excessive Leakage:** Disassemble valve (see Maintenance) and clean all parts. If parts are worn or damaged, install a complete ASCO Rebuild Kit.

Valve Disassembly

1. Disassemble valve using exploded views for identification of parts.
2. Remove solenoid, see separate instructions.
3. Unscrew solenoid base sub-assembly or valve bonnet with special wrench adapter supplied in ASCO Rebuild Kit. For wrench adapter only, order No. K218948. Remove core assembly, core spring, and solenoid base gasket from valve body. For normal maintenance on Series 8263 valves it is not necessary to remove valve seat. See Figure 1 for metering or manual operator constructions.
4. For normally open construction (Figure 3) remove end cap, or manual operator, (not shown) end cap gasket, disc holder spring, and disc holder assembly.
5. All parts are now accessible to clean or replace. If parts are worn or damaged, install a complete ASCO Rebuild Kit.

Valve Reassembly

1. Use exploded views for identification, orientation and placement of parts.
2. Lubricate all gaskets with DOW CORNING® 111 Compound lubricant or an equivalent high-grade silicone grease.
3. For normally open construction (Figure 3), install disc holder assembly, disc holder spring, end cap gasket and end cap or manual operator. For valves with 1/8" NPT, torque end cap or manual operator to 90 ± 10 in-lbs [10.2 ± 1.1 Nm]. For all other valves torque end cap or manual operator to 175 ± 25 in-lbs [19.8 ± 2.8 Nm].
4. For Series 8263 apply a small amount of LOCTITE® PST® pipe sealant to threads of valve seat (if removed). Follow manufacturers instructions for application of pipe sealant. Then install valve seat and torque to 75 ± 10 in-lbs [8.5 ± 1.1 Nm].
5. Replace solenoid base gasket, core assembly with core spring and solenoid base sub-assembly or plugnut/core tube sub-assembly and valve bonnet. Note: For core assemblies with internal type core springs, install wide end of core spring in core assembly first, closed end of core spring protrudes from top of core assembly.
6. For 1/8" NPT valve constructions, Torque valve bonnet to 90 ± 10 in-lbs [10.2 ± 1.1 Nm]. Torque solenoid base sub-assembly to 175 ± 25 in-lbs [19.8 ± 2.8 Nm].
7. Install solenoid, see separate solenoid instructions. Then make electrical hookup to solenoid.

▲ WARNING: To prevent the possibility of death, serious injury or property damage, check valve for proper operation before returning to service. Also perform internal seat and external leakage tests with a nonhazardous, noncombustible fluid.

8. Restore line pressure and electrical power supply to valve.
9. After maintenance is completed, operate the valve a few times to be sure of proper operation. A metallic *click* signifies the solenoid is operating.

ORDERING INFORMATION FOR ASCO REBUILD KITS

Parts marked with an asterisk (*) in the exploded view are supplied in Rebuild Kits. When Ordering Rebuild Kits for ASCO valves, order the Rebuild Kit number stamped on the valve nameplate. If the number of the kit is not visible, order by indicating the number of kits required, and the Catalog Number and Serial Number of the valve(s) for which they are intended.

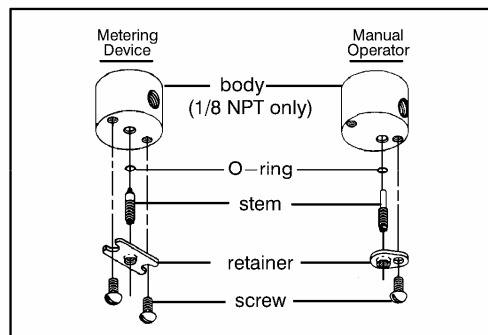

Figure 1. Metering and manual operator constructions.

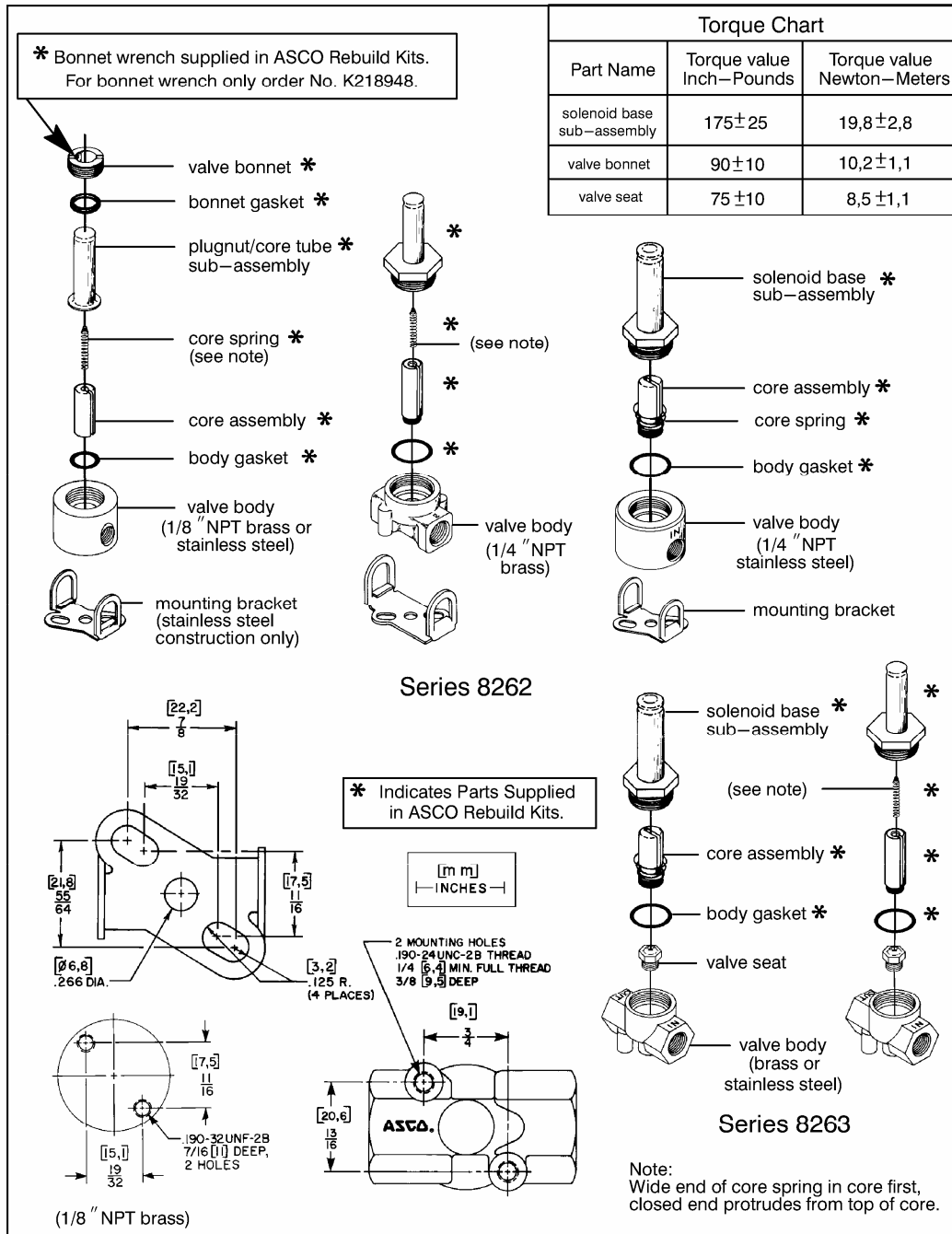

Figure 2. Series 8262 and 8263, normally closed construction.

Disassembly and Reassembly of Stem /Lever Type Manual Operator (Refer to Figure 3)

NOTE: There are two stem/lever manual operator constructions. They are identified by the location of the core spring as *internal* or *external* spring construction.

1. Unscrew solenoid base sub-assembly from manual operator body.
2. Unscrew manual operator body from valve body. Then remove body gasket and stem retainer.
3. Slip stem/spacer sub-assembly with stem gasket from manual operator body. Remove core assembly with core spring from center of manual operator body.
4. All parts are now accessible for cleaning or replacement. Lubricate gaskets per *Valve Reassembly* step 2.

5. Position core assembly with core spring into base of manual operator body. Then install stem/spacer sub-assembly into manual operator body to engage with core assembly.
6. Reinstall stem retainer on body and stem/spacer sub-assembly.

IMPORTANT: The spacer on the stem/spacer sub-assembly must be *inside* of the stem retainer for *internal* spring construction and *outside* of the stem retainer for *external* spring construction.

7. Replace body gasket and install manual operator assembly in valve body. Torque manual operator body to 175 ± 25 in-lbs [$19,8 \pm 2,8$ Nm].
8. Replace solenoid base gasket and solenoid base sub-assembly. Torque solenoid base sub-assembly to 175 ± 25 in-lbs [$19,8 \pm 2,8$ Nm].
9. Check manual operator for proper operation. Turn stem clockwise and counterclockwise; stem should turn freely without binding.

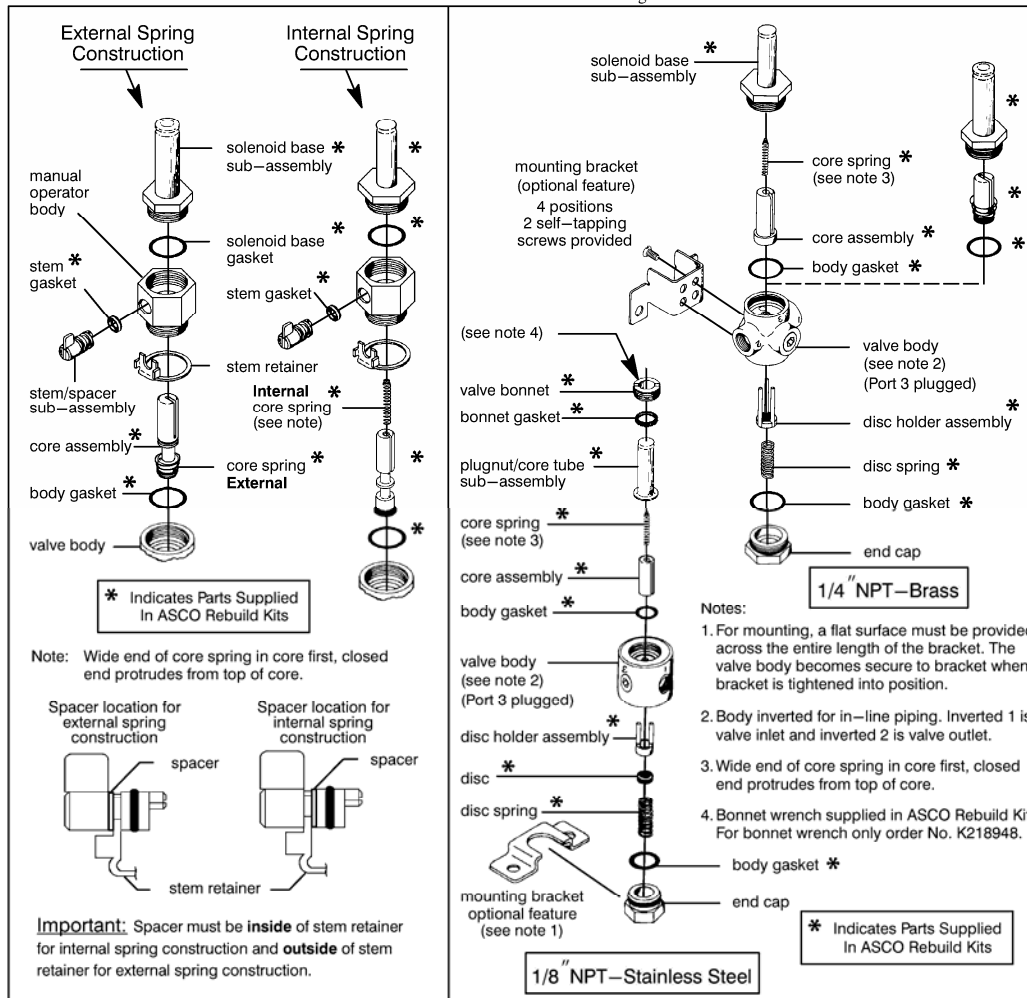

Figure 3. Stem/lever type manual operators

Figure 4. Series 8262, normally open construction.

INSTALLATION & MAINTENANCE INSTRUCTIONS

2-WAY DIRECT-ACTING SOLENOID VALVES
SUB-MINIATURE - NORMALLY CLOSED OPERATION
BRASS OR STAINLESS STEEL CONSTRUCTION - 1/8 NPT

V6332R3



SERIES
8225

DESCRIPTION

Series 8225 valves are 2-way normally closed, direct-acting solenoid valves made of rugged brass or stainless steel. Valves are sub-miniature in size and are provided with an open-frame solenoid.

OPTIONAL FEATURES

Mounting Bracket Kit No. 224-736: This kit provides mounting of valves for ease of installation, removal and adjustment to piping (See Figure 2).

Plug Connector Kit No. 226-061: The open-frame solenoid with spade terminal connections may be used with the plug connector kit providing a 2-pole with grounding contact Type 3 x DiN 46244 construction (See Figure 4).

Conduit Connector Kit No. 224-735: The open-frame solenoid with lead wires may be converted to gasketed threaded conduit hub enclosure for watertight or general purpose construction (See Figure 5).

OPERATION

Normally Closed: Valve is closed when solenoid is de-energized. Valve is open when solenoid is energized.

IMPORTANT: No minimum operating pressure required.

INSTALLATION

Check nameplate for correct catalog number, pressure, voltage frequency and service. Never apply incompatible fluids or exceed pressure rating of the valve. Installation and valve maintenance to be performed by qualified personnel.

FUTURE SERVICE CONSIDERATIONS

Provisions should be made for performing seat leakage, external leakage and operational tests on the valve with a nonhazardous, noncombustible fluid after disassembly and reassembly.

POSITIONING

This valve is designed to perform properly when mounted in any position. However, for optimum life and performance, the solenoid should be mounted vertically and upright to reduce the possibility of foreign matter accumulating in the plugnut/core tube sub-assembly area.

MOUNTING

For valve body mounting dimensions refer to Figure 1. For dimensions of mounting bracket supplied in Mounting Bracket Kit No. 224-736, refer to Figure 2.

PIPING

Connect piping to valve according to markings on valve body. Inlet port is marked "1" and outlet port is marked "2". Apply pipe compound sparingly to male pipe threads only. If applied to valve threads the compound may enter the valve and cause operational difficulty. Avoid pipe strain by properly supporting and aligning piping. When tightening the pipe, do not use valve or solenoid as a lever! Locate wrenches applied to valve body or piping as close as possible to connection point.

⚠ CAUTION: To protect the solenoid valve, install a strainer or filter, suitable for the service involved, in the inlet side as close to the valve as possible. Clean periodically depending on service conditions. See ASCO Bulletins 8600, 8601 and 8602 for strainers.

WIRING

Wiring must comply with local codes and the National Electrical Code.

NOTE: To convert from Alternating Current (A-C) to Direct Current (D-C) or vice versa, it is necessary to change only the coil. However, the valve pressure rating will change. Consult ASCO Catalog.

SOLENOID TEMPERATURE

Coils for Bulletin 8225 valves are designed for continuous duty. When solenoid is energized for a long period, the solenoid enclosure becomes hot and can be touched by hand only for an instant. This is a safe operating temperature. Any excessive heating will be indicated by the smoke and odour of burning coil insulation.

MAINTENANCE

NOTE: It is not necessary to remove the valve from the pipeline for inspecting, cleaning or coil replacement.

⚠ WARNING: To prevent the possibility of personal injury or property damage, turn off electrical power, depressurize valve and vent fluid to a safe area before servicing the valve.

CLEANING

All solenoid valves should be cleaned periodically. The time between cleanings will vary depending on the medium and service conditions. In general, if the voltage to the coil is correct, sluggish valve operation, excessive noise or leakage will indicate that cleaning is required. In the extreme case faulty valve operation will occur and the valve may fail to open or close. Clean valve strainer or filter when cleaning the valve.

PREVENTIVE MAINTENANCE

1. Keep the medium flowing through the valve as free from dirt and foreign material as possible.
2. While in service, the valve should be operated at least once a month to insure proper opening and closing.

CAUSES OF IMPROPER OPERATION

1. **Faulty Control Circuit:** Check the electrical system by energizing the coil. A metallic "click" signifies that the solenoid is operating. Absence of the "click" indicates loss of power supply. Check for loose or blown fuses, open-circuited or grounded coil, broken lead wires or splice connections.
2. **Burned-Out Coil:** Check for open-circuited coil. Replace coil if necessary. Check supply voltage; it must be the same as specified on nameplate.
3. **Low Voltage:** Check voltage across the coil leads. Voltage must be at least 85% of nameplate rating.
4. **Incorrect Pressure:** Check valve pressure. Pressure to valve must be within range specified on nameplate.
5. **Excessive Leakage:** Disassemble valve (see MAINTENANCE) and clean all parts. If parts are worn or damaged, replace valve. See Ordering Information.

COIL REPLACEMENT (Refer to Figure 3)

⚠ WARNING: Turn-off electrical power supply and depressurize valve. Then proceed as follows:

1. Disconnect coil lead wires
2. Remove clip
3. Slip coil off plugnut/core tube sub-assembly
4. Install new coil and replace clip
5. Make electrical hook-up and restore electrical power

VALVE DISASSEMBLY FOR INSPECTING AND CLEANING

(Refer to Figure 3)

⚠ WARNING: Turn-off electrical power supply and depressurize valve. Then proceed as follows:

1. Disassemble valve in an orderly fashion. Use exploded view for identification and placement of parts.
2. Disconnect coil lead wires
3. Remove clip
4. Slip coil off plugnut/core tube sub-assembly
5. Remove mounting screws, cover, plugnut/core tube sub-assembly, gasket and core assembly with core spring
6. All parts are now accessible for cleaning

VALVE REASSEMBLY

1. Reassemble in reverse order of disassembly. Use exploded view for identification and placement of parts.
2. Lubricate gasket with DOW CORNING® 111 Compound lubricant or an equivalent high-grade silicone grease.
NOTE: If core spring has been removed from core assembly, be sure to install small diameter end of core spring on core assembly first. The core spring should snap in place and remain engaged.
3. Replace core assembly, core spring, gasket, plugnut/core tube sub-assembly, cover and mounting screws. Torque mounting screws in a crisscross manner to 9 ± 2 inch-pounds (1.0 ± 0.2 newton-meters).
4. Replace coil and retaining spring. Make electrical hook-up and restore electrical power and line pressure.
5. After maintenance is completed, operate the valve a few times to be sure of proper operation.



AJN1231696-332

V6332R3 (page 1 of 2)

© Automatic Switch Co. MCMXCVI All Rights Reserved Printed in The Netherlands

⚠ WARNING: To prevent the possibility of personal injury or property damage, check valve for proper operation before returning to service. Also perform internal seat and external leakage tests with a nonhazardous, noncombustible fluid.

INSTALLATION OF PLUG CONNECTOR KIT NO. 226-061
(Refer to Figure 4)

1. Remove center screw from plug connector. Using a small screwdriver pry terminal block from connector housing.
2. Use stranded copper wire rated at 90°C or greater for connections. Maximum wire size is Number 18 AWG. Strip wire leads back approximately 1/4-inch for installation in socket terminals. The use of wire-end sleeves is also recommended for these socket terminals. Maximum length of wire-end sleeves to be approximately 1/4-inch. Tinning of the ends of the lead wires is not recommended.
3. Thread wire through gland nut, gland gasket, washer and connector housing. NOTE: Connector housing may be rotated 180° from position shown in Figure 4 for alternate positioning of cable entry.

4. Make electrical hook-up to terminal block. Snap terminal block into connector housing and replace center screw.
5. Position gasket on coil and install plug connector. Torque center screw to 5 ± 2 inch-pounds [0,6 ± 0,2 newton-meters].

INSTALLATION OF CONDUIT CONNECTOR KIT NO. 224-735
(Refer to Figure 5)

1. Thread coil lead wires through connector gasket and conduit connector.
2. Position gasket and conduit connector against coil and install center screw. Torque center screw to 5 ± 2 inch-pounds [0,6 ± 0,2 newton-meters].

ORDERING INFORMATION FOR NEW COILS OR VALVES

When ordering specify coil number or valve catalog number, serial number, voltage and frequency.

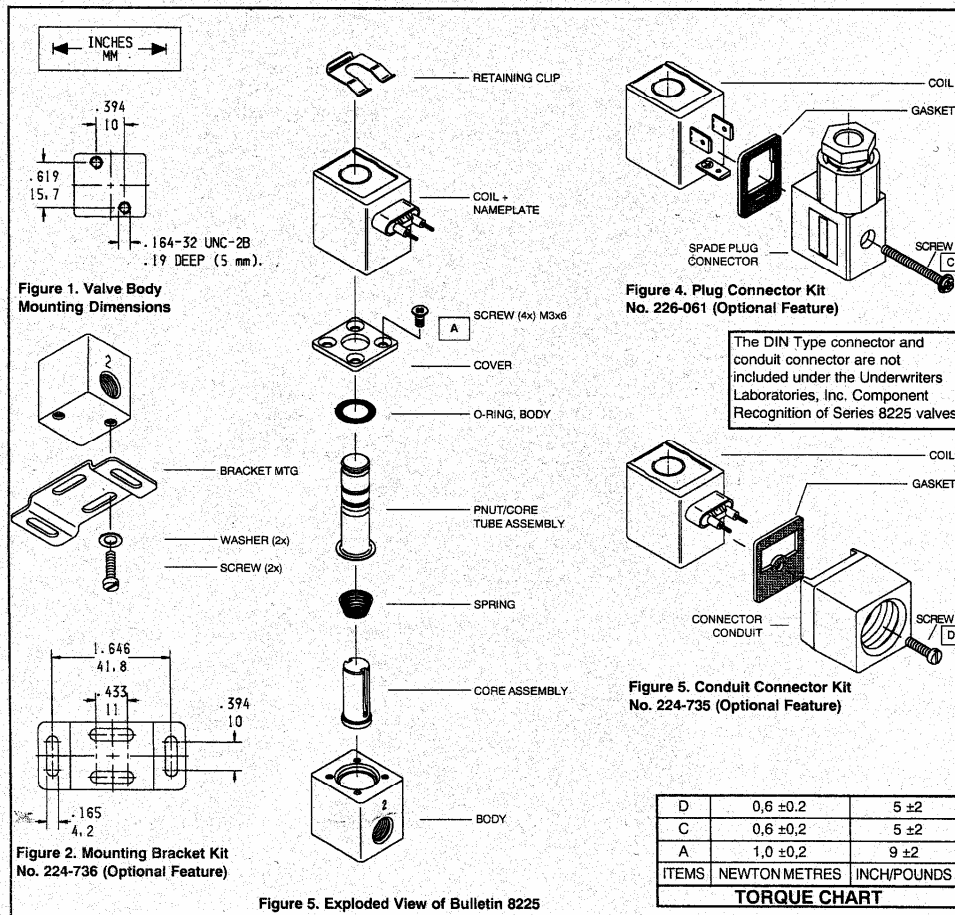

Automatic Switch Co. 50-60 Hanover Road,
Florham Park, NJ 07932, USA